

User Manual
GPS Motorcycle Tracker
(Version V1.1)



Introducing Your Device

Learn about your device's layout, indications and specifications.

1 Inside the Box



Pictures are for indication and illustration purposes only.

NOTE:

After opening the packing box, please check if the accessories are complete. If there is anything missing, please contact your distributor.

2 Overview

2.1 Introduction



2.2 LED Indication

2.2.1 Red LED (power/working status indicator)

Status	Meaning
Quick flashing	Low battery
Slow flashing	Fully charged
Continuously in bright	Charging
Continuously in dark	No battery/troubleshoot

2.2.2 Blue LED (GPS signal indicator)

Status	Meaning
Quick flashing	Searching GPS signal
Slow flashing	GPS signal has been acquired successfully
Continuously in dark	GPS stops working

2.2.3 Green LED(GSM signal indicator)

Status	Meaning
Quick flashing	GSM initialization
Slow flashing	GPRS online
Continuously in dark	No GSM signal or no SIM card installed

2.3 Armed

When red/green/blue 3 LED lights are flashing twice in cycle, it means the terminal is armed.

2.4 Function of the wires

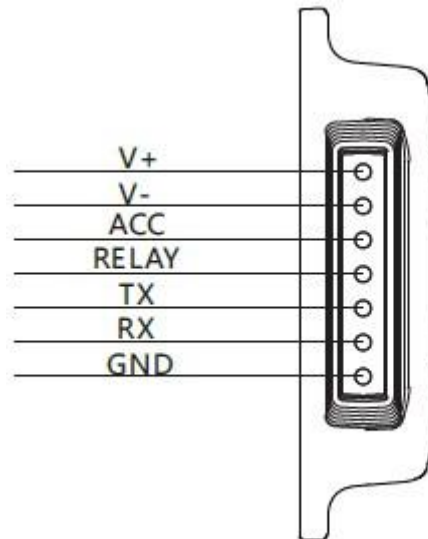

No.	Function	Color	Function Illustration
1	V+	Red	Positive pole
2	V-	Black	Negative pole
3	ACC	Orange	ACC on
4	Relay	Yellow	Relay controlled wire
5	TX	Green	Send data / for backup
6	RX	Blue	Receive data / for backup
7	GND	Purple	Ground wire

3 Installation

3.1 Placement

The terminal should be placed under cover. It is recommended to ask professional companies to install the terminal for you.

1. Best place to install

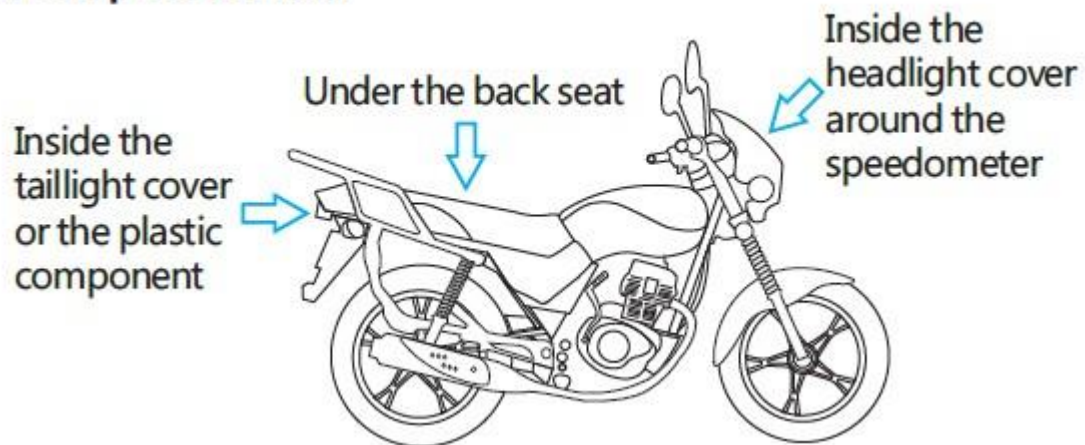

2. Best place to install

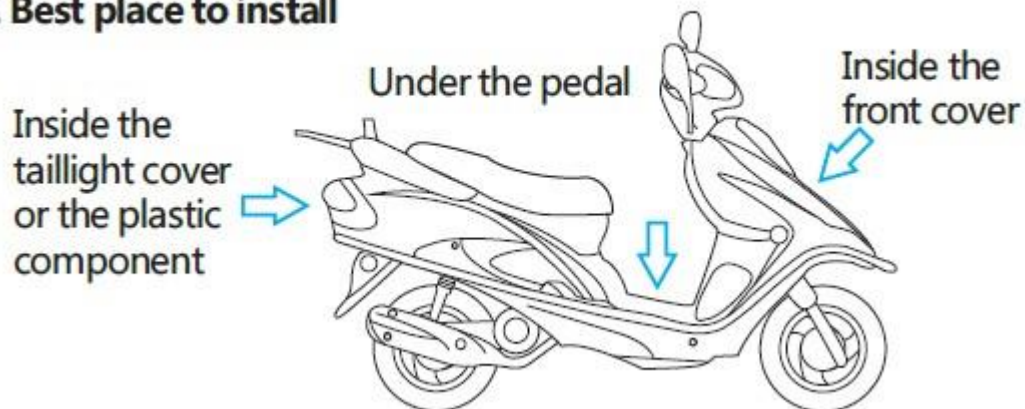

NOTE: The GPS signal will be attenuated if the device is installed under the driver seat.

3.2 Wiring

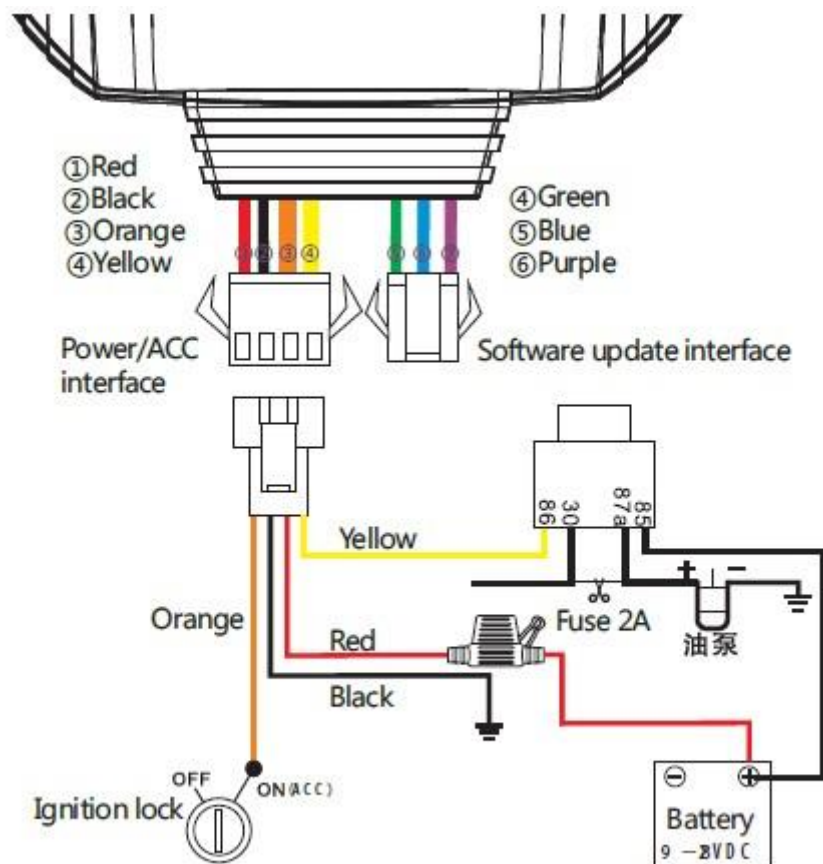

- (1) Use multimeter to find out the negative pole of the battery.
- (2) Use multimeter to find out the ACC wire. Method: Use the red pen to connect with the ACC wire while the black pen connects with the ground wire. In this condition, when the ignition lock is off, the voltage is 0; when the ignition lock is turned on, the multimeter will show the voltage.
- (3) The red line (positive pole) of the terminal cable should be connected to the positive pole of the battery.
- (4) Follow the picture above to connect the wires.
- (5) When the terminal is connected to external power, insert the SIM card into the terminal and the red indicator (power indicator) should be normally on. When the ignition lock is turned off, the red indicator should be flashing slowly.
- (6) The yellow wire of the relay control line should be connected to the 86 as the picture shows.

4 Power ON/OFF

4.1 Power ON

The terminal will be automatically on when you insert the SIM card into the SIM card slot. The battery will connect the internal wires together in the terminal and the external power supply will start providing power to the device and also charging the battery.

After the power is on, it will start searching the GSM and GPS signal. During this period, the green indicator (GSM indicator) will be flashing while the blue indicator (GPS indicator) will be flashing quickly. When the blue indicator is flashing slowly, it means GPS has located.

4.2 Power OFF

Pull out the SIM card, the terminal will be off.

5 Parameters setting

5.1 Set APN

Please inquire about the APN with your SIM card operator and send SMS command to the number of terminal so as to set up the APN parameter. The terminal will reply "OK" automatically after setting successfully.

Send SMS command: **APN,APN's name#**

e.g: **APN,internet#**

NOTE: The APN of some countries have user name and password, you may need to send SMS command as follows:

Send SMS command: **APN,APN's name,user name,password#**

e.g: **APN,internet,CLIENTE,AMENA#**

5.2 Set DNS

Please send SMS command to the number of terminal so as to set up the DNS parameter. The terminal will reply "OK" automatically after setting successfully.

Send SMS command: **SERVER,1,DNS,Port,0#**

e.g. **SERVER,1,et100.szdatasource.com,8841,0#**

5.3 Set SOS Number

(1) Add SOS number Via SMS command

Send SMS command: **SOS,A,number1,number2,number3 #**(A means add number).

You can set 3 SOS numbers in maximum. If set successfully, the terminal will reply "ok".

e.g. **SOS,A,13510****60,135116****6,136126****8#** (set all 3 SOS numbers)

SOS,A,13510**60#** (set the first SOS number)

SOS,A, ,135116**6#** (set the second SOS number)

SOS,A, , ,136126**8#** (set the third SOS number)

(2) Delete SOS Numbers

Send SMS command: **SOS,D,1,2,3#** (D means delete SOS number)

e.g. **SOS,D,1#** means delete the first number

SOS,D,3# means delete the third number

If you do not know the sequence number, you can also delete the number by SMS command like this: **SOS,D,number#**

e.g. **SOS,D, 135278****0#** means delete this SOS number directly.

It will reply "OK" if the number is deleted successfully.

(3) Add SOS numbers via platform

You can set SOS number via the platform after activating the terminal.

5.4 Set Center Number

Send SMS command from the SOS number to set the Center Number.

(1) Add Center Number:

Send SMS command: **CENTER,A,number#**

e.g. **CENTER,A,135278****0#**

(2) Delete Center Number

Send SMS command: **CENTER,D,number#**

e.g. **CENTER,D,135278****0#**

NOTE: Center Number can be set ONLY by SOS numbers.

5.5 Check current parameters

Send SMS command: **PARAM#**

The terminal will reply messages including: IMEI number, GPRS upload interval, time interval that GPS is activated when ACC is off, SOS numbers, center number, sensor alarm interval, defense time and time zone.

5.6 Set GPS data upload interval

(1) Upload by interval

The default upload interval is 20 seconds, which means every 20 seconds the terminal will upload its location data to the platform. The interval can be set by sending SMS command: **TIMER,T1,T2#** ($5 \leq T \leq 18000$ seconds)

e.g. **TIMER,20,30#**

It means when ACC is on, GPS data upload interval is 20 seconds; when ACC is off, GPS data upload interval is 30 seconds.

(2) Upload by distance

Send SMS command: **DISTANCE,D#** ($100 \leq D \leq 10000$ meters)

e.g. **DISTANCE,300#**

It means for every 300 meters, the terminal will upload GPS data to platform.

NOTE: if the upload interval is short, the GPRS current will add up. Please set the suitable upload interval.

5.7 Corners upload (ON as default)

The terminal will upload GPS data to the platform when the vehicle is turning (the turning angle reaches the pre-set value).

NOTE: if the speed is too low during turning, the GPS data will be not able to upload to the platform.

Send SMS command: **ANGLEREP,OFF#** to turn it off.

5.8 Arm time interval

When the vehicle is turned off (ACC low) and stays off in 3 minutes, the terminal will enter arm status. During this status, if the terminal detects 6 vibrations (default) and the vehicle still stays off (ACC off) in 30 seconds, it will activate vibration alarm.

Send SMS command: **DEFENSE,T#** ($1 \leq T \leq 60$ minutes)

e.g. **DEFENSE,15#**

It means after 15 minutes the vehicle is turned off, the terminal will enter defense mode.

5.9 Reboot the terminal

Send SMS command: **RESET#**

When the terminal receives the command, it will reboot in 20 seconds.

6 Operation

6.1 Check location

(1) Ask for coordinates

Send SMS command from SOS number to the terminal: **WHERE#**

Only SOS number can apply for replying longitude and latitude from the terminal. If GPS is located, it will reply latest longitude and latitude information.

e.g. Lat:N22.571285,Lon:E113.877115,Course:42.20,Speed:0.0740,DateTime:10-11-23 22:28

If GPS is not located at all, the terminal will reply: "NO DATA!"

(2) Ask for Google link

Send SMS command from SOS number to the terminal: **URL#**

If GPS is located, it will reply google link of latest longitude and latitude.

e.g. Google link reply

"<DateTime:10-11-23 23:42:51>

<http://maps.google.com/maps?q=N22.571490,E113.877103>"

(3) Check platform

The terminal will send position information to the platform server timely. Users can check the position on the platform.

The platform website: www.cootrack.net

Please contact your supplier for the login methods and operations.

6.2 Vibration Alarm (ON as default)

When the vehicle is turned off (ACC low) and stays off for 3 minutes (pre-set), the terminal will enter arm status. During this time, if the terminal detects 6 times vibrations (default) and the vehicle still stays off (ACC off) in 30 seconds, it will activate vibration alarm. The terminal will upload longitude and latitude data to the platform. Then the platform will send the google link to SOS number.

e.g. GPS information link:

"vibration alarm: <DateTime:10-11-23 23:42:51>

<http://maps.google.com/maps?q=N22.571490,E113.877103>"

If you do not want to receive vibration alarm messages, send SMS command: **SENALM,OFF#** to turn it off.

6.3 Cable cut-off Alarm (ON as default)

When the terminal cable is cut off, the cable cut-off alarm will be activated. The terminal will send the alarm to the platform and upload longitude and latitude data. And the platform will send google link to SOS number.

e.g. GPS information link:

“Cut Power! <DateTime:10-11-23 23:42:51>

<http://maps.google.com/maps?q=N22.571490,E113.877103>”

Send SMS command: **POWERALM,OFF#** to turn it off.

6.4 Low Battery Alarm (ON as default)

When the battery is low, the terminal will send SMS to SOS numbers and upload alarm information to platform.

Send SMS command: **BATALM,OFF#** to turn off the alarm.

6.5 Moving alarm (OFF as default)

Send SMS command: **MOVING,ON,R#** ($100 \leq R \leq 1000$ meters, 300 is recommended)

In the situation where ACC becomes low, if the vehicle is moved over 300 meters (pre-set) from the latest location, the terminal will send moving alarm to the platform. SOS number will receive moving alarm message.

e.g.

“Attention! The vehicle is moved. <DateTime:10-11-2323:42:51>

<http://maps.google.com/maps?q=N22.571490,E113.877103>”

Send SMS command: **MOVING,OFF#** to turn off the alarm

6.6 Petrol cut-off

(1) Cut-off petrol

When the vehicle was stolen, you can cut off the petrol on the platform in the situation where the GPS has located and the speed is under 20km/h. Platform password is needed. Or you can send SMS command to the device.

Send SMS command: **RELAY,1#** to cut off petrol.

(2) Restore petrol

You can restore petrol on the platform. Platform password is needed.

Send SMS command: **RELAY,0#** to restore petrol.

NOTE: Petrol cut-off and restore commands can be executed by the center number ONLY.

7 Trouble shooting

If there is any problem while operating the terminal, please refer to the following table, or contact your supplier.

Common problems	Causes	Solution
Bad reception	Near the tall building or in the basement	Change to a place with good signal
The terminal cannot be turned on	No battery power	Change a new battery
Cannot connect to the network	SIM card is not inserted correctly	Check the SIM card
	The sheet mental of SIM card is Dusty	Wipe it clean
	Invalid SIM card	Contact your SIM card operator
	Out of GSM service area	Move back to the GSM service covered area.
	Weak signal	Try again in a strong signal area
Cannot charge	Voltage is out of charging range of the charger	Change to the proper voltage
	Poor contact	Check if the plug is in
Cannot check address information	GPRS function is not activated	Please contact the SIM card operator to activate GPRS
	Cannot get the position data	①restart the terminal ②contact with your supplier
	It is not a SOS number	set SOS number