



# **FM1100 User Manual v0.15**

## Table of contents

<b>1</b>	<b>INTRODUCTION .....</b>	<b>5</b>
1.1	ATTENTION .....	5
1.2	INSTRUCTIONS OF SAFETY .....	5
1.3	LEGAL NOTICE .....	6
1.4	ABOUT DOCUMENT .....	6
<b>2</b>	<b>BASIC DESCRIPTION .....</b>	<b>6</b>
2.1	PACKAGE CONTENTS .....	7
2.2	BASIC CHARACTERISTICS .....	7
2.3	MECHANICAL FEATURES .....	8
2.4	ELECTRICAL CHARACTERISTICS .....	10
2.5	ABSOLUTE MAXIMUM RATINGS .....	10
<b>3</b>	<b>CONNECTION, PINOUT, ACCESSORIES .....</b>	<b>11</b>
3.1	SIM CARD INSERT SCHEME .....	11
3.2	INSTALLING FM1100 DRIVERS .....	12
3.3	NAVIGATE LED .....	14
3.4	STATUS LED .....	14
3.5	SOCKET 2×5 .....	14
3.6	USB .....	15
3.7	ACCESSORIES .....	15
<b>4</b>	<b>FIRMWARE .....</b>	<b>19</b>
4.1	UPDATING FIRMWARE USING USB CABLE .....	19
4.2	UPDATING FIRMWARE VIA GPRS .....	20
<b>5</b>	<b>OPERATIONAL BASICS .....</b>	<b>21</b>
5.1	OPERATIONAL PRINCIPALS .....	21
5.2	DEEP SLEEP MODE .....	21
5.3	VIRTUAL ODOMETER .....	22
5.4	FEATURES .....	22
5.4.1	<i>Scenarios</i> .....	22
5.4.2	<i>Trip</i> .....	23
5.4.3	<i>Geofencing</i> .....	23
5.4.4	<i>iButton list</i> .....	23
5.5	CONFIGURATION .....	24
5.6	CONFIGURATOR .....	24
5.7	SYSTEM SETTINGS .....	25
5.8	RECORDS SETTINGS .....	26
5.9	GSM SETTINGS, GPRS PART .....	26
5.10	GSM SETTINGS, SMS PART .....	27
5.11	GSM SETTINGS, OPERATOR LIST .....	27
5.12	DATA ACQUISITION MODE SETTINGS .....	28
5.13	FEATURES SETTINGS .....	31
5.13.1	<i>Scenarios settings</i> .....	32
5.13.2	<i>Trip settings</i> .....	33
5.13.3	<i>Geofencing settings</i> .....	34
5.14	I/O SETTINGS .....	36
5.14.1	<i>Monitoring</i> .....	38
5.14.2	<i>Event Generating</i> .....	38
5.14.3	<i>Hysteresis</i> .....	39
<b>6</b>	<b>SMS COMMAND LIST .....</b>	<b>40</b>
6.1	SMS COMMAND LIST .....	40
6.1.1	<i>getstatus</i> .....	41

6.1.2	<i>getweektime</i> .....	41
6.1.3	<i>getops</i> .....	41
6.1.4	<i>getcfgtime</i> .....	41
6.1.5	<i>getgps</i> .....	42
6.1.6	<i>getver</i> .....	42
6.1.7	<i>getinfo</i> .....	42
6.1.8	<i>getio</i> .....	43
6.1.9	<i>readio #</i> .....	43
6.1.10	<i>setdigout ##</i> .....	43
6.1.11	<i>getparam ####</i> .....	43
6.1.12	<i>setparam #### #</i> .....	43
6.1.13	<i>flush #,#,#,#,#,#</i> .....	44
<b>7</b>	<b>DEBUG MODE</b> .....	<b>45</b>
<b>8</b>	<b>PARAMETER LIST</b> .....	<b>46</b>
8.1	PARAMETERS VALUE TYPES.....	46
8.2	SYSTEM PARAMETERS .....	46
8.2.1	<i>Deep Sleep Mode (ID=1000)</i> .....	46
8.2.2	<i>Analog Input value range (ID=1001)</i> .....	46
8.2.3	<i>Stop Detection Source (ID=1002)</i> .....	46
8.3	RECORDS PARAMETERS .....	46
8.3.1	<i>Sorting (ID=1010)</i> .....	46
8.3.2	<i>Active Data Link Timeout (ID=1011)</i> .....	47
8.4	GSM PARAMETERS .....	47
8.4.1	<i>GPRS content activation (ID=1240)</i> .....	47
8.4.2	<i>APN Name (ID=1242)</i> .....	47
8.4.3	<i>APN username (ID=1243)</i> .....	47
8.4.4	<i>APN Password (ID=1244)</i> .....	47
8.4.5	<i>Target Server IP address (ID=1245)</i> .....	48
8.4.6	<i>Target Server Port (ID=1246)</i> .....	48
8.4.7	<i>Protocol (ID=1247)</i> .....	48
8.4.8	<i>SMS Login (ID=1252)</i> .....	48
8.4.9	<i>SMS Password (ID=1253)</i> .....	48
8.4.10	<i>SMS data sending settings (ID=1250)</i> .....	49
8.4.11	<i>SMS Data send week time schedule (ID=1273)</i> .....	49
8.4.12	<i>Authorized phone numbers (ID=1260-1269)</i> .....	49
8.4.13	<i>Operator List (ID=1271)</i> .....	49
8.5	DATA ACQUISITION MODES PARAMETERS.....	49
8.5.1	<b>Home Network GSM operator code "Vehicle on STOP" parameters</b> .....	49
8.5.1.1	Min Period (ID=1540).....	49
8.5.1.2	Min Saved Records (ID=1543).....	50
8.5.1.3	Send Period (ID=1544) .....	50
8.5.1.4	GPRS Week Time (ID=1545).....	50
8.5.2	<b>Home Network GSM operator code "Vehicle MOVING" parameters</b> .....	50
8.5.2.1	Min Period (ID=1550).....	50
8.5.2.2	Min Distance (ID=1551) .....	51
8.5.2.3	Min Angle (ID=1552).....	51
8.5.2.4	Min Saved Records (ID=1553).....	51
8.5.2.5	Send Period (ID=1554) .....	51
8.5.2.6	GPRS Week Time (ID=1555).....	51
8.5.3	<b>Roaming Network GSM operator code "Vehicle on STOP" parameters</b> .....	52
8.5.3.1	Min Period (ID=1560).....	52
8.5.3.2	Min Saved Records (ID=1563).....	52
8.5.3.3	Send Period (ID=1564) .....	52
8.5.3.4	GPRS Week Time (ID=1565).....	52
8.5.4	<b>Roaming Network GSM operator code "Vehicle MOVING" parameters</b> .....	52
8.5.4.1	Min Period (ID=1570).....	52
8.5.4.2	Min Distance (ID=1571) .....	52
8.5.4.3	Min Angle (ID=1572).....	53

8.5.4.4	Min Saved Records (ID=1573)	53
8.5.4.5	Send Period (ID=1574)	53
8.5.4.6	GPRS Week Time (ID=1575)	53
8.5.5	<b>Unknown Network GSM operator code "Vehicle on STOP" parameters</b>	53
8.5.5.1	Min Period (ID=1580)	53
8.5.5.2	Min Saved Records (ID=1583)	53
8.5.5.3	Send Period (ID=1584)	54
8.5.5.4	GPRS Week Time (ID=1585)	54
8.5.6	<b>Unknown Network GSM operator code "Vehicle MOVING" parameters</b>	54
8.5.6.1	Min Period (ID=1590)	54
8.5.6.2	Min Distance (ID=1591)	54
8.5.6.3	Min Angle (ID=1592)	54
8.5.6.4	Min Saved Records (ID=1593)	55
8.5.6.5	Send Period (ID=1594)	55
8.5.6.6	GPRS Week Time (ID=1595)	55
8.6	<b>FEATURES PARAMETERS</b>	55
8.6.1	<i>Digital Output No.1 usage scenarios (ID=1600)</i>	55
8.6.1	<i>Max Acceleration Force (ID=1602)</i>	55
8.6.2	<i>Max Braking Force (ID=1603)</i>	55
8.6.3	<i>Max Cornering Angle (ID=1604)</i>	56
8.6.4	<i>Max allowed Speed (ID=1605)</i>	56
8.6.5	<i>Digital Output No.2 usage scenarios (ID=1601)</i>	56
8.6.6	<i>Trip (ID=1280)</i>	56
8.6.7	<i>Start Speed (ID=1281)</i>	56
8.6.8	<i>Ignition Off Timeout (ID=1282)</i>	56
8.6.9	<i>Trip Continuous distance counting (ID=1283)</i>	57
8.6.10	<i>Geofencing</i>	57
8.6.10.1	Frame border (ID=1020)	57
8.6.10.2	Geofence Zone #1 Shape (ID=1030)	57
8.6.10.3	Geofence Zone #1 Priority (ID=1031)	57
8.6.10.4	Geofence Zone #1 Generate Event (ID=1032)	57
8.6.10.5	Geofence Zone #1 Longitude (X1) (ID=1033)	57
8.6.10.6	Geofence Zone #1 Latitude (Y1) (ID=1034)	58
8.6.10.7	Geofence Zone #1 Longitude (X2) (ID=1035)	58
8.6.10.8	Geofence Zone #1 Latitude (Y2) (ID=1036)	58
8.6.11	<i>AutoGeofencing</i>	59
8.6.11.1	Enable/Disable (ID=1101)	59
8.6.11.2	Activation Timeout (ID=1102)	59
8.6.11.3	Deactivate by (ID=1100)	59
8.6.11.4	AutoGeofence event Priority (ID=1103)	59
8.6.11.5	AutoGeofence event generating (ID=1104)	59
8.6.11.6	Radius (ID=1105)	59
8.6.12	<i>iButton List (ID=1610-1659)</i>	60
8.7	<b>IO PARAMETERS</b>	60
8.7.1	<i>IO#1 property parameter (ID=1300)</i>	60
8.7.2	<i>IO#1 priority (ID=1301)</i>	60
8.7.3	<i>IO#1 High level (ID=1302)</i>	60
8.7.4	<i>IO#1 Low level (ID=1303)</i>	61
8.7.5	<i>IO#1 logic operand (ID=1304)</i>	61
8.7.6	<i>IO#1 averaging length (ID=1305)</i>	61
9	<b>MOUNTING RECOMMENDATIONS</b>	63
9.1	CONNECTING WIRES	63
9.2	CONNECTING POWER SOURCE	63
9.3	CONNECTING IGNITION WIRE	63
9.4	CONNECTING GROUND WIRE	63
9.5	CONNECTING ANTENNAS	63
9.6	MODULE INSTALLATION	64
10	<b>CHANGE LOG</b>	65

## 1 INTRODUCTION

### 1.1 Attention



Do not disassemble the device. If the device is damaged, the power supply cables are not isolated or the isolation is damaged, before unplugging the power supply, do not touch the device.



All wireless data transferring devices produce interference that may affect other devices which are placed nearby.



The device must be connected only by qualified personnel.



The device must be firmly fastened in the predefined location.



The programming must be performed using a second class PC (with autonomic power supply).



The device is susceptible to water and humidity.



Any installation and/or handling during a lightning storm are prohibited.



FM1100 has USB interface;  
Please use cables provided with FM1100 device.  
Teltonika is not responsible for any harm caused by using wrong cables for PC <-> FM1100 connection.

### 1.2 Instructions of safety

This chapter contains information on how to operate FM1100 safely. By following these requirements and recommendations, you will avoid dangerous situations. You must read these instructions carefully and follow them strictly before operating the device!

The device uses a 10 V...30 V DC power supply. The nominal voltage is 12 V DC. The allowed range of voltage is 10 V...30 V DC.

To avoid mechanical damage, it is advised to transport the FM1100 device in an impact-proof package. Before usage, the device should be placed so that its LED indicators are visible, which show the status of operation the device is in.

When connecting the connection (2x5) cables to the vehicle, the appropriate jumpers of the power supply of the vehicle should be disconnected.

Before dismounting the device from the vehicle, the 2x5 connection must be disconnected.

The device is designed to be mounted in a zone of limited access, which is inaccessible for the operator. All related devices must meet the requirements of standard EN 60950-1.

The device FM1100 is not designed as a navigational device for boats.

### **1.3 Legal Notice**

Copyright © 2011 Teltonika. All rights reserved. Reproduction, transfer, distribution or storage of part or all of the contents in this document in any form without the prior written permission of Teltonika is prohibited.

Other products and company names mentioned here may be trademarks or trade names of their respective owners.

### **1.4 About document**

This document contains information about the architecture, possibilities, mechanical characteristics, and configuration of the FM1100 device.

Acronyms and terms used in document

PC – Personal Computer.

GPRS – General Packet Radio Service.

GPS – Global Positioning System.

GSM – Global System for Mobile Communications.

SMS – Short Message Service.

AC/DC – Alternating Current/Direct Current.

I/O – Input/Output.

Record – AVL data stored in FM1100 memory. AVL data contains GPS and I/O information

AVL packet - Data packet that is being sent to server during data transmission. AVL packet contains from 1 to 24 records.

## **2 BASIC DESCRIPTION**

FM1100 is a terminal with GPS and GSM connectivity, which is able to determine the object's coordinates and transfer them via the GSM network. This device is perfectly suitable for applications, which need location acquirement of remote objects. It is important to mention that FM1100 has additional inputs and outputs, which let you control and monitor other devices on remote objects. FM1100 also has a USB port for device status log output and entering configurations.

## 2.1 *Package contents*<sup>1</sup>

The FM1100 device is supplied to the customer in a cardboard box containing all the equipment that is necessary for operation. The package contains:

- FM1100 device;
- input and output power supply cable with a 2x5 connection pins;
- GPS antenna;
- GSM antenna;
- USB cable;
- card with link to drivers and configurator.

## 2.2 *Basic characteristics*

GSM / GPRS features:

- Teltonika TM11Q quad band module (GSM 850 / 900 / 1800 / 1900 MHz);
- GPRS class 10;
- SMS (text, data).

GPS features:

- Skytraq (Venus634LPx chipset) 65 channel receiver;
- Protocol NMEA-0183: GGA, GGL, GSA, GSV, RMC, VTG;
- Up to -161 dBm sensitivity.

Hardware features:

- Cortex<sup>®</sup>-M3 processor;
- 1 MB internal Flash memory;
- Built-in movement sensor.

Interface features:

- Power supply: 10 ÷ 30V;
- USB port;
- 3 digital inputs;
- 1 analog input;
- 2 open collector digital outputs;
- 1Wire<sup>®</sup> temperature sensor
- 1Wire<sup>®</sup> iButton
- LEDs indicating device status.

Special features:

- Any element event triggers (external sensor, input, speed, temperature, etc.);
- Highly configurable data acquisition and sending;
- Multiple Geo-fence areas;
- Deep sleep mode;
- Configurable scenarios available;

---

<sup>1</sup> Package content depends on Order Code, and can be customized by customer needs.

- Real-time process monitoring;
- Authorized number list for remote access;
- Firmware update over GPRS or USB port;
- Configuration update over GPRS, SMS or USB port;
- TCP/IP or UDP/IP protocol support;
- 8000 record storing;

### 2.3 Mechanical features

Part name	Physical specification	Technical details
Navigation LED	LED	Power supply 10...30 V DC 2W Max Energy consumption: GPRS: --- 150 mA r.m.s Max., Nominal: --- average 65 mA r.m.s, Deep Sleep: --- average less than 2 mA <sup>2</sup> Operation temperature: -25°C ... +55°C Storage temperature: -40°C ... +70°C Storage relative humidity 5 ... 95 % (non condensation)
Modem LED	LED	
GPS	GPS antenna connector MCX	
GSM	GSM antenna connector SMA female outer shell, female inner pin	
Socket 2x5	Tyco Micro MATE-N-LOK™ 4-794628-0 or similar	
USB	Mini USB socket	

Table 1. FM1100 specifications

<sup>2</sup> When in Deep Sleep mode no data storing and sending is activated.

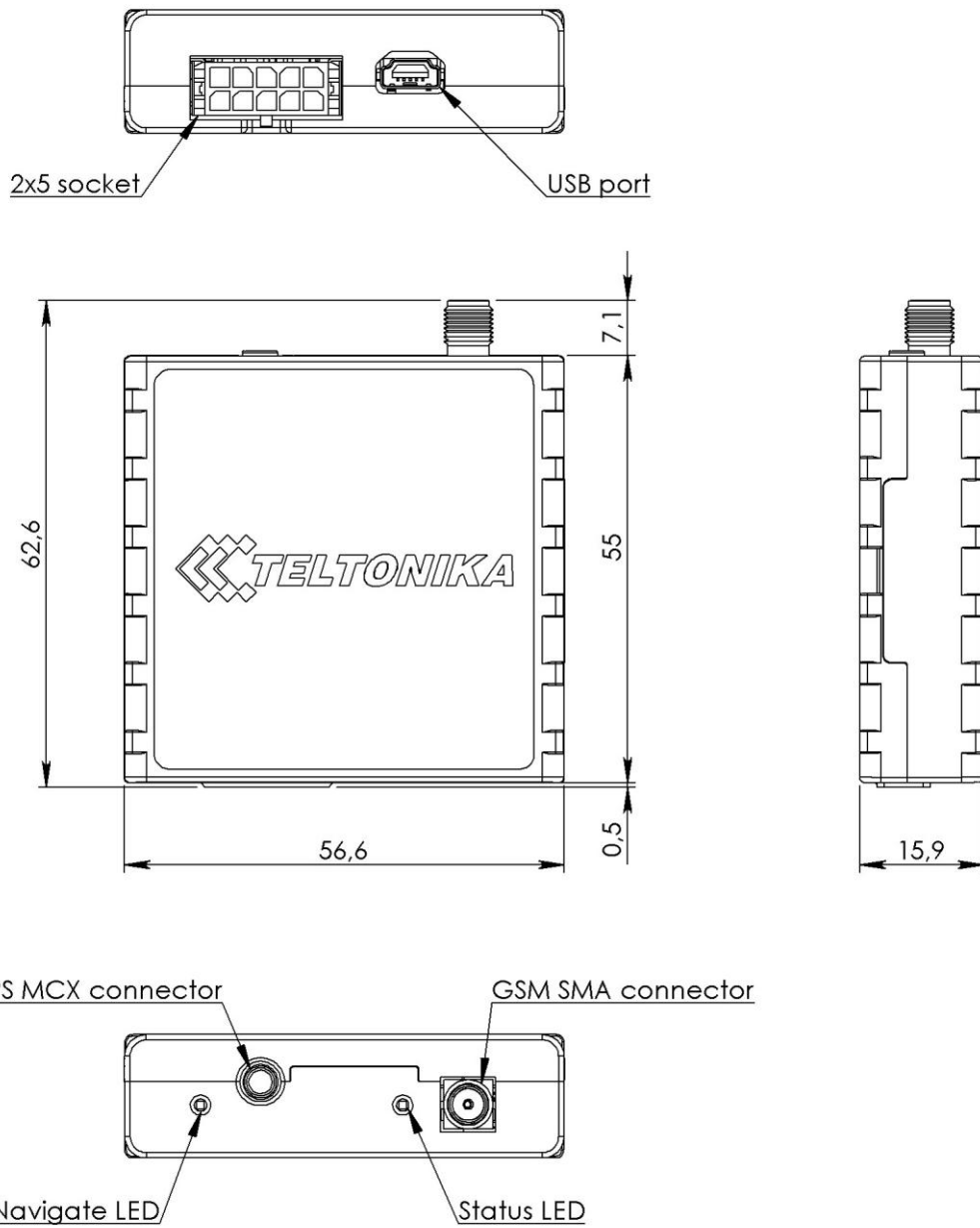

Figure 2. FM1100 view & dimensions (tolerance  $\pm 2\text{mm}$ )

## 2.4 Electrical characteristics

	Min.	Typ.	Max.	Unit
Supply Voltage:				
Supply Voltage (Recommended Operating Conditions)	10		30	V
Digital Output (Open Drain grade):				
Drain current (Digital Output OFF)			120	uA
Drain current (Digital Output ON, Recommended Operating Conditions)			300	mA
Static Drain-Source resistance (Digital Output ON)			300	mOhm
Digital Input:				
Input resistance (DIN1, DIN2, DIN3)	15			kOhm
Input Voltage (Recommended Operating Conditions)	0		Supply voltage	V
Input Voltage threshold (DIN1)		7,5		V
Input Voltage threshold (DIN2, DIN3)		2,5		V
Analog Input:				
Input Voltage (Recommended Operating Conditions), Range1	0		10	V
Input resistance, Range1		120		kOhm
Input Voltage (Recommended Operating Conditions) Range2	0		30	V
Input resistance, Range2		146,7		kOhm
Output Supply Voltage 1-Wire: <sup>3</sup>				
Supply Voltage	3,3		3,6	V
Output inner resistance		7		Ohm
Output current ( $U_{out} > 3.0V$ )		30		mA
Short circuit current ( $U_{out} = 0$ )		130		mA

## 2.5 Absolute Maximum Ratings

Supply Voltage (Absolute Maximum Ratings)	-32		32	V
Drain-Source clamp threshold voltage (Absolute Maximum Ratings), ( $I_{drain} = 2mA$ )			36	V
Digital Input Voltage (Absolute Maximum Ratings)	-32		32	V
Analog Input Voltage (Absolute Maximum Ratings)	-32		32	V

<sup>3</sup> 1-wire Supply voltage PIN is dedicated for 1-wire devices ONLY, do not use it for any other purpose.

### 3 CONNECTION, PINOUT, ACCESSORIES

#### 3.1 SIM card insert scheme

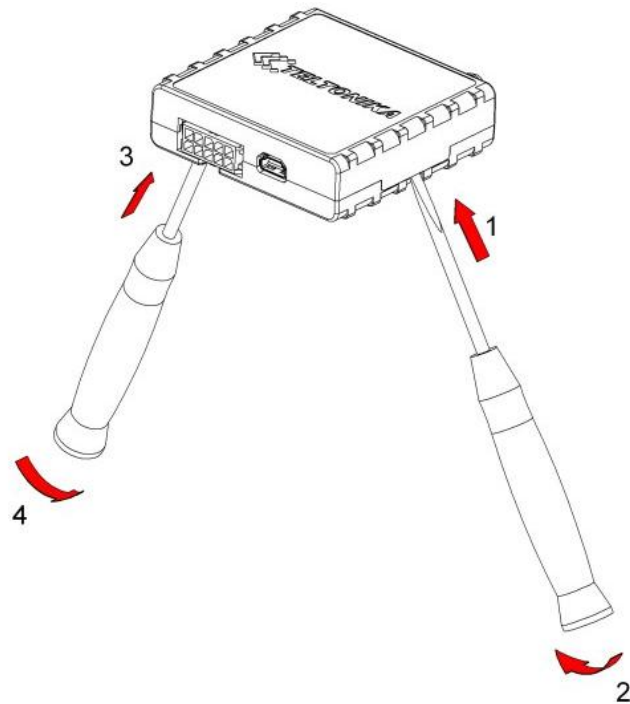

①

Gently open FM1100 case using screwdrivers

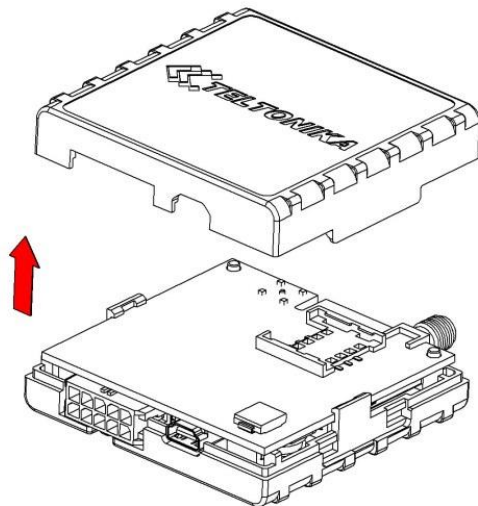

②

Take off FM1100 case

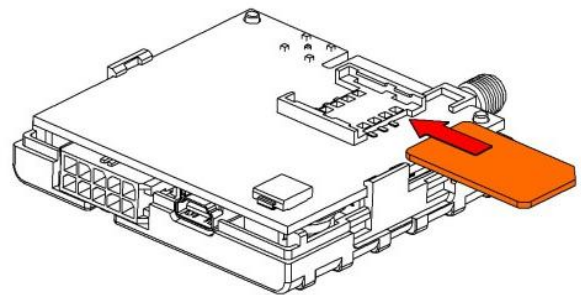

③

Insert SIM card as shown

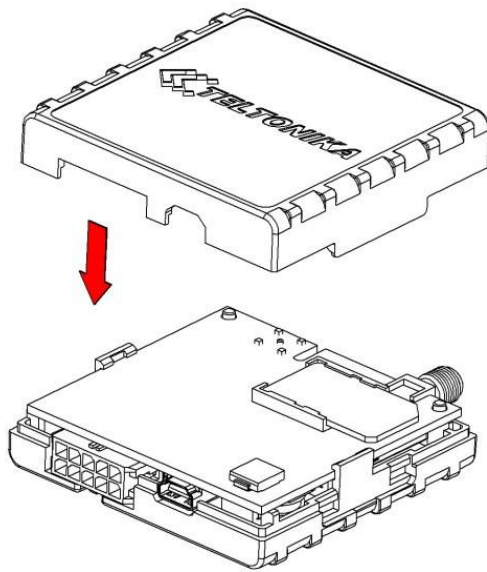

④

Assemble devices top part

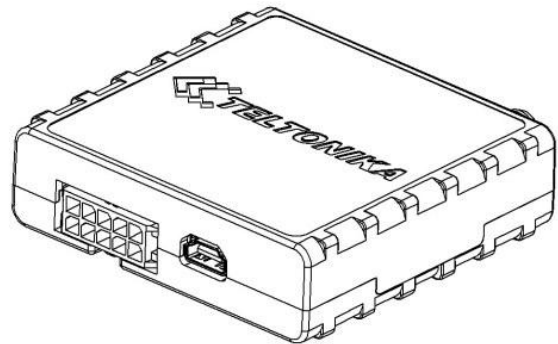

⑤

Device is ready

### 3.2 Installing FM1100 drivers

#### Software requirements

- Operating system 32-bit and 64-bit: Windows XP with SP3 or later, Windows Vista, Windows 7.
- MS .NET Framework V3.5 or later (<http://www.microsoft.com> or <http://av11.teltonika.lt/downloads/tav/Framework/dotnetfx35setupSP1.zip>).

#### Drivers

Please download Virtual COM Port drivers from Teltonika website: [http://av11.teltonika.lt/downloads/FM11/vcpdriver\\_v1.3.1\\_setup.zip](http://av11.teltonika.lt/downloads/FM11/vcpdriver_v1.3.1_setup.zip)

#### Installing drivers

Extract and run VCPDriver\_V1.3.1\_Setup.exe. This driver is used to detect FM1100 device connected to the computer. Click 'Next' in driver installation window (figures below):

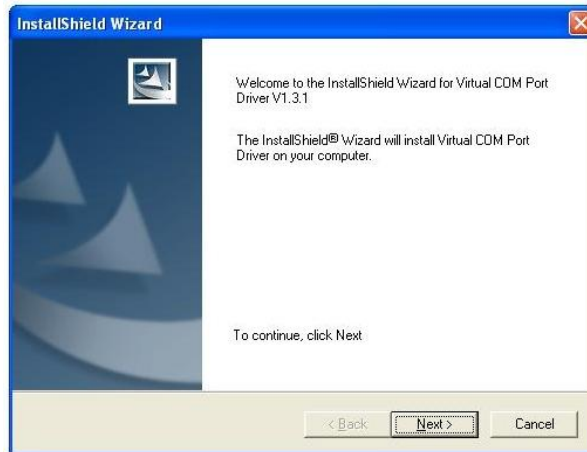

**Figure 3. Driver installation window**

This will launch device driver installation wizard. In the following window click 'Next' button again:



**Figure 4. Driver installation window**

Setup will continue installing drivers and will display a window about successful process in the end. Click 'Finish' to complete setup:



**Figure 5. Driver installation window**

You have now installed drivers for FM1100 device successfully.

### 3.3 Navigate LED

Behaviour	Meaning
Permanently switched on	GPS signal is not received
Blinking every second	Normal mode, GPS is working
Off	GPS is turned off because: <ul style="list-style-type: none"> <li>• Deep sleep mode</li> </ul> Or <ul style="list-style-type: none"> <li>• GPS antenna short circuited</li> </ul>

### 3.4 Status LED

Behaviour	Meaning
Blinking every second	Normal mode
Blinking every 2 seconds	Deep sleep mode
Blinking fast for a short time	Modem activity
Blinking fast constantly	Boot mode
Off	<ul style="list-style-type: none"> <li>• Device is not working</li> </ul> Or <ul style="list-style-type: none"> <li>• Device firmware being flashed</li> </ul>

### 3.5 Socket 2x5

DIN 1 (IGNITION)	5		10	Ucc_DALLAS
DIN 2	4		9	DIN 3
OUT 1	3		8	DATA_DALLAS
OUT 2	2		7	AIN 1
VCC (10÷30)V DC (+)	1		6	GND (VCC (10÷30)V DC (-))

Figure 6. 2x5 socket pinout

Pin Nr.	Pin Name	Description
1	2	3
1	VCC (10÷30)V DC (+)	Power supply for module. Power supply range (10...30) V DC
2	OUT 2	Digital output. Channel 2. Open collector output. Max. $\overline{I}$ 300mA.
3	OUT 1	Digital output. Channel 1. Open collector output. Max. $\overline{I}$ 300mA.
4	DIN 2	Digital input, channel 2
5	DIN 1	Digital input, channel 1 DEDICATED FOR IGNITION INPUT
6	GND(VCC(10÷30)V DC)(-)	Ground pin. (10÷30)V DC (—)
7	AIN 1	Analog input, channel 1. Input range: 0-30V/0-10V DC
8	DATA_DALLAS	Data channel for Dallas 1-Wire® devices
9	DIN 3	Digital input, channel 3
10	Ucc_DALLAS	+ 3,8 V output for Dallas 1-Wire® devices. (max 20mA)

Table 2. Socket 2x5 pinout description.

### 3.6 USB

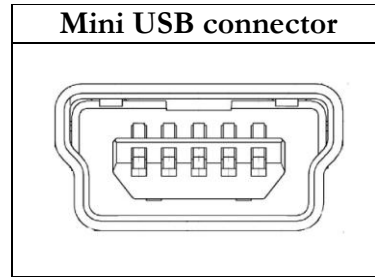

Figure 7. Mini USB type B connector

FM1100 connected to PC creates STM Virtual COM Port, which can be used as system port (to flash firmware and configure the device).

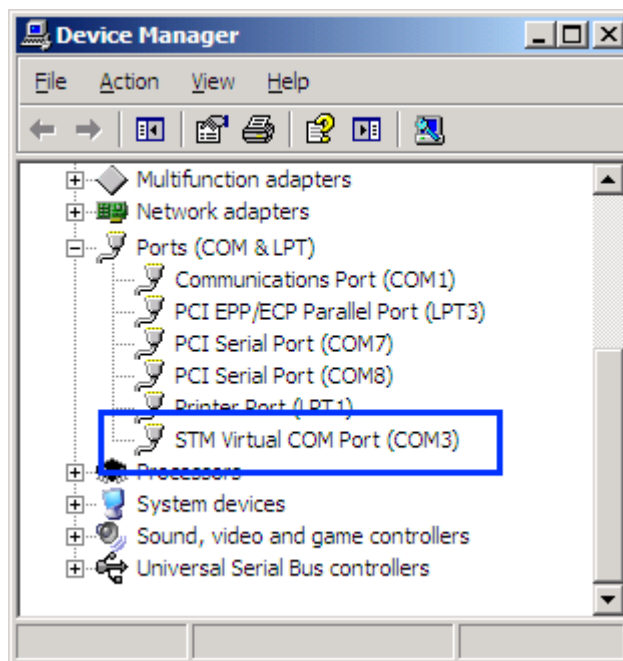

Figure 8. COM-Ports

### 3.7 Accessories



Note: Teltonika does not provide any additional equipment like panic buttons, door sensors or others.

### 1 – Wire devices

One of the FM1100 features is realized 1-Wire® data protocol, which enables connection of thermometer (DS1820, DS18S20 and DS18B20) and I-Button type: [DS1990A](#). Figures 9 and 10 shows FM1100 and 1-wire® devices connection schemes.

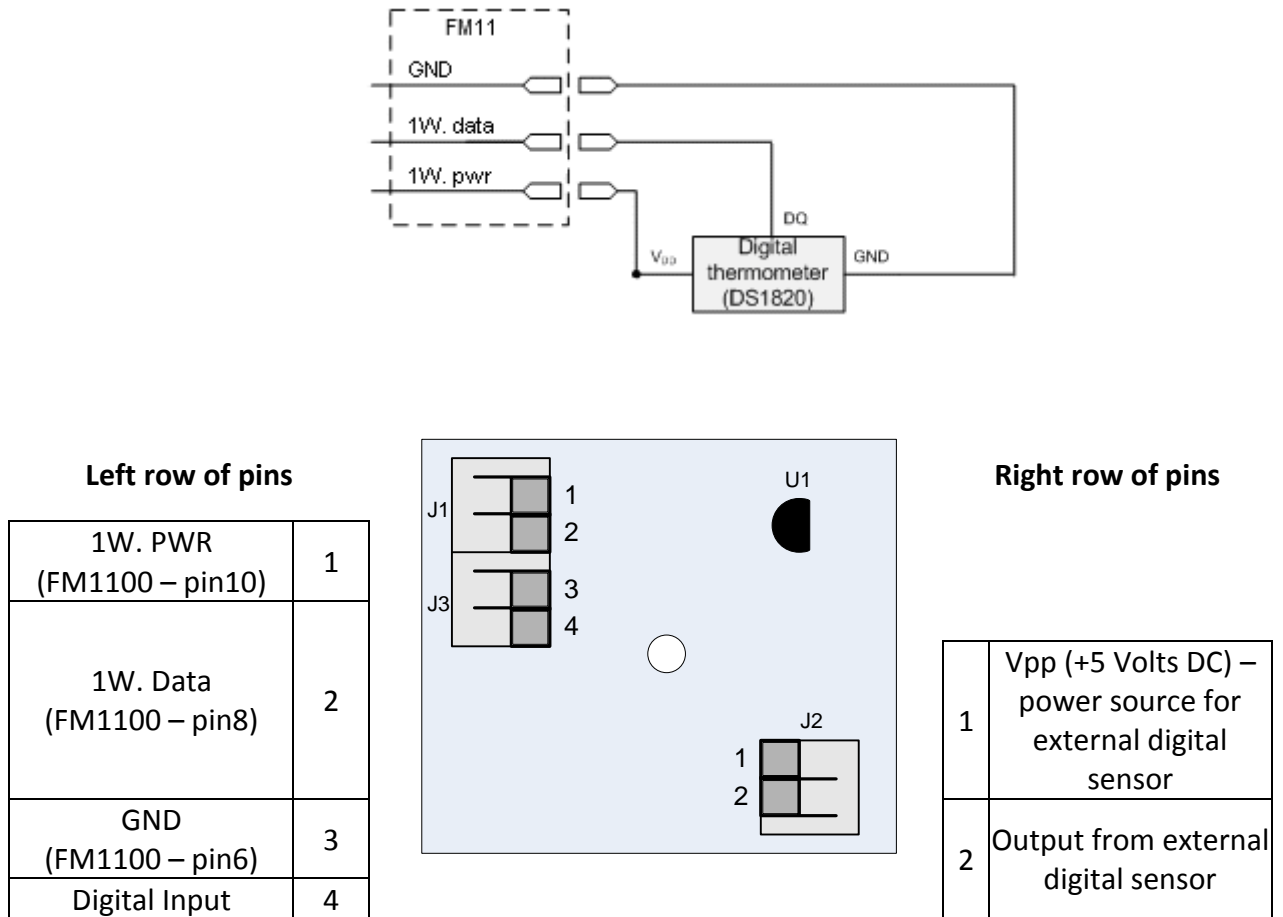

Figure 9. Digital thermometer DS1820 and TTI100 connection scheme

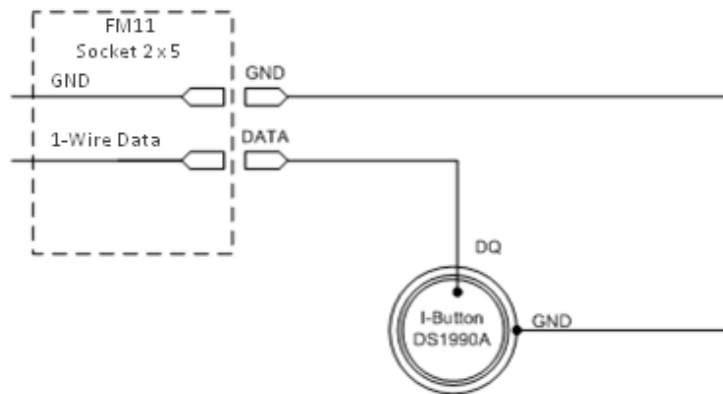
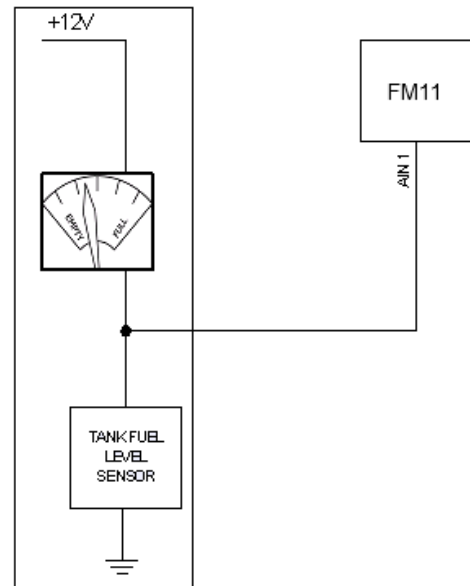

Figure 10. I-Button DS1990A connection scheme

### Fuel Tank sensors

A fuel tank level sensor exists in most of the cars, which shows the approximate fuel level in the driver's indicator panel. It is possible to connect FM1100 Analog input (if sensor returns analogue signal proportional to fuel level). Figure shows the connection scheme to the FM1100 and fuel tank sensor. After the connection to the tank fuel level sensor, calibration is needed. Calibrations needed due of the fact that most fuel tank sensors are not linear. Calibration is being performing by measuring voltage dependence on volume of fuel in tank.



### Alarm buttons, door sensors, etc.

Alarm buttons, door sensors, ignition, etc. return two states: high or low voltage. Digital inputs are used to read this information. Figure below shows how to connect alarm button, door sensor, etc.

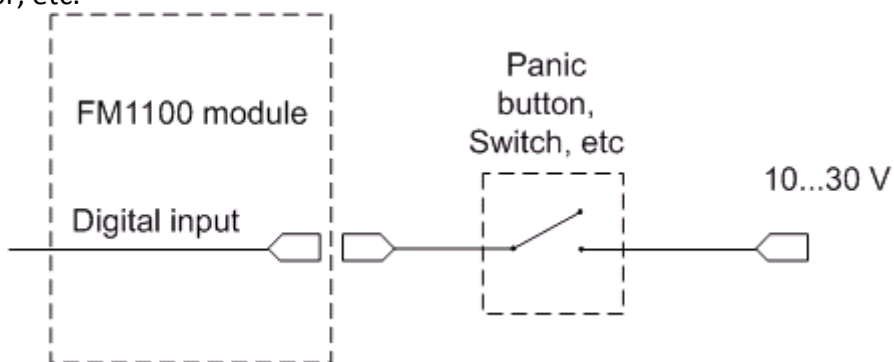

Figure 11. Panic button connection

In cases when sensor output signal is negative, an additional relay has to be installed to convert negative signal to positive.

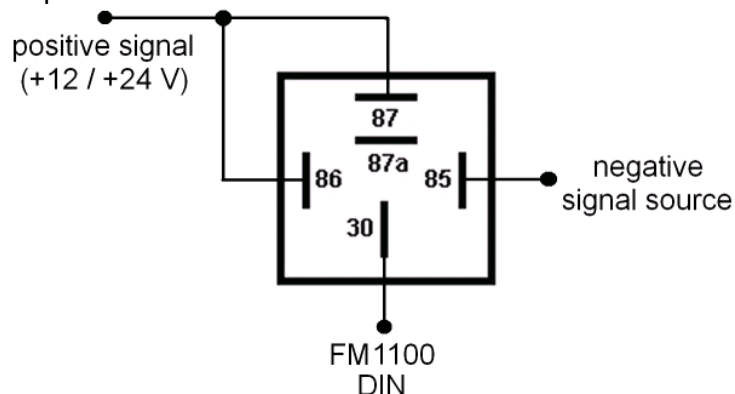

Figure 12. Inverting relay connection

## Immobilizer relay

When connected as shown below, FM1100 disables engine starter when output is ON. More details about relays can be found below.

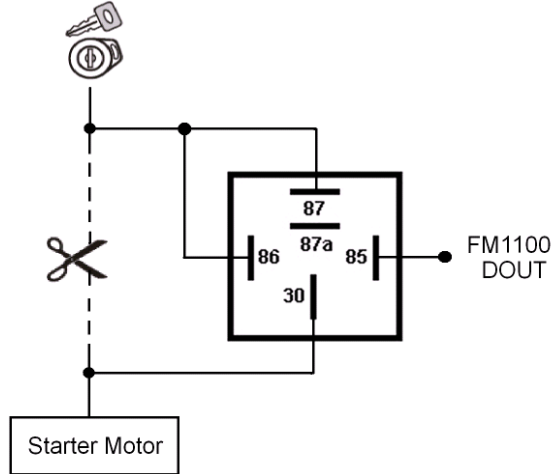

Figure 13. Immobilizer relay connection

## Relays

A simple automotive relay is used to invert input signal or to immobilize engine starter. Note, that they are available as 12 V or 24 V.

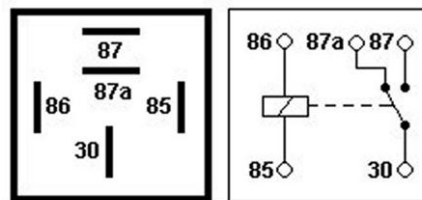

Figure 14. Automotive relay pinout

## 4 FIRMWARE

### 4.1 Updating firmware using USB cable

FM1100 functionality is always improving, new firmware versions are developed. Current module firmware version can be retrieved from configurator. See configuration description for details.

Contact sales manager to get the latest firmware.

Updater is needed to update the firmware. It can be downloaded from:

<http://avl1.teltonika.lt/downloads/FM11/>

Firmware must to be copied to “Firmware updater” folder.

Connect FM1100 to PC with USB cable. Launch “Firmware Updater”, select COM port, click connect and update. Update process may take up to several minutes.

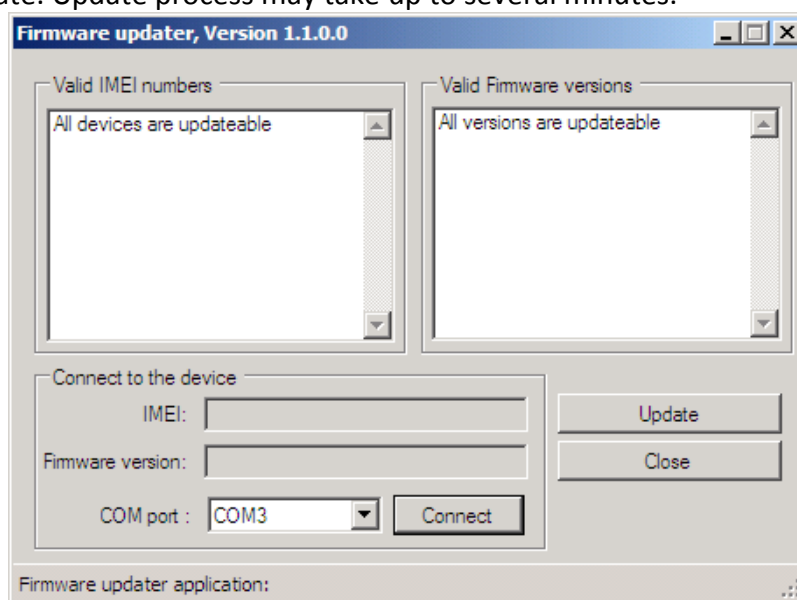

Figure 15. FM updater screen

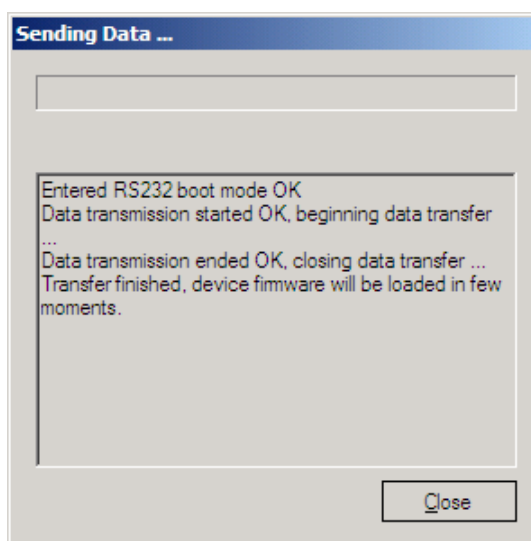

Figure 16. FM firmware updating finished

## 4.2 Updating firmware via GPRS

Firmware can also be updated over GPRS using RILS system.

RILS stands for Remote Imlet Loading System, which is used to update FM1100 processor firmware. In order to update firmware, server sends a SMS to the FM1100 and directs it to connect to the server and download new firmware. The special web interface is used for this operation. Address of the web application is: <http://212.47.99.62:5002/RILS-web/>.

For RILS login and password please contact your sales manager.

After logging in click on 'Upload FM4', click Browse, select FM1100 firmware file from hard disk, click OK and then Upload. Select uploaded firmware from the list (last one) and click next. Enter necessary parameters in the fields:

1. Server IP: 212.47.99.62
2. Server port: 5009
3. Module number is GSM number of FM SIM in worldwide standard, for example: +37069912345.

Enter your APN, APN (chap) login and password. After entering all parameters, click 'Add Module'. To operate multiple devices, enter new IMEI and GSM number and click 'Add Module' again. Otherwise click 'Next' and if all data is correct, in next window click 'Upload'.

## 5 OPERATIONAL BASICS

### 5.1 Operational principals

FM1100 module is designed to acquire records and send them to the server. Records contain GPS and I/O information. Module uses GPS receiver to acquire GPS data and is powered with three data acquire methods: time-based, distance-based and angle-based method. Method's details are described in 5.12 section. All data is stored in flash memory and later can be sent via GPRS or SMS channels. GPRS mode is most preferred data sending mode. SMS mode is mostly used in areas without GPRS coverage or GPRS usage is too expensive.

GPRS and SMS settings are described in later sections. FM1100 communicates with server using special data protocol. Data protocol is described in "FMXXXX Protocols" document.

FM1100 can be managed by SMS commands. SMS Command list is described in SMS COMMAND LIST section. Module configuration can be performed over TCP or via SMS. Configuration parameters and modes are described in "FMXXXX Protocols" document.

### 5.2 Deep Sleep mode

While in deep sleep mode, FM1100 sets GPS receiver to sleep mode and turns off GSM/GPRS module (it is not possible to wake up device via SMS), therefore records with last good coordinates are being saved and send to AVL server if configured (GSM/GPRS module is turned on to send data and after turned off). Depending on two configurable parameters, send period and min period, in Deep Sleep mode power usage can be decreased to save vehicle's battery.

FM1100 can enter deep sleep mode (standby mode) if **ALL** of these conditions are met:

- FM1100 has to be configured to work in Deep Sleep mode;
- Startup timeout has elapsed (5 minutes after every restart of the device);
- No movement by movement sensor is detected;
- Ignition (DIN1) is off (driven logic low);
- Send period in stop mode is more than 60 seconds (Data Acquisition Mode settings);
- USB cable is not connected.

FM1100 exits deep sleep mode when if **ONE** of following conditions are true:

- Movement by movement sensor is detected;
- Ignition (DIN1) is turned on (driven logic high);
- USB cable is connected;



Note: In order to save GPRS traffic records saved in deep sleep mode do not contain below listed I/O elements information:

PDOP, HDOP, Odometer, Speedometer, iButton ID, Cell ID, Area Code, Temperature and GPS power

### 5.3 Virtual odometer

Virtual odometer is used to calculate traveled distance in FM1100 as a separate I/O element. When FM1100 detects movement, it starts counting distance using GPS signal: every second it checks current location and calculates distance between current and previous point. It keeps adding these intervals until it is time to make a record, then FM1100 records its location and adds odometer value, which is equal to the sum of all distances, measured every second. When record is made, odometer resets to zero and distance calculation starts all over again.

Virtual odometer as an I/O element can be also used with Trip feature, read 5.4.2 and 5.13.2 chapters.

### 5.4 Features

Using available features can greatly increase FM1100 usability options.

#### 5.4.1 Scenarios

Four scenarios are available on FM11 device.

Digital Output No.1 is used by scenarios - Green Driving **or** Over Speeding;

Digital Output No.2 is used by scenarios - Authorized Driving **or** Immobilizer.

**Green Driving Scenario.** Helps to prevent and inspect driver about harsh driving. Scenario continuously monitors: accelerating force, braking force and cornering angles. Inspects driver if needed. DOUT1 is controlled by scenario for user needs, for example buzzer or LED.

To save GPRS traffic Green Driving event will be **generated (included into send records) only** when FM1100 measured values are higher than those set in configuration, without additional I/O settings.

To prevent generating false events, harsh acceleration and harsh braking is monitored only when following conditions are fulfilled:

- Ignition is ON (DIN1 = 1)
- Vehicle speed is equal or higher than 10km/h

Harsh cornering is monitored only when following conditions are fulfilled:

- Ignition is ON (DIN1 = 1)
- Vehicle speed is equal or higher than 30km/h



Note: Green Driving Scenario is in on various cars and various drivers testing phase and can be subject to changes. Teltonika is constantly working on improvement of the functionality of the devices, and strongly recommends using the latest version of the firmware.

**Over Speeding Scenario.** Helps to prevent from exceeding fixed speed and inspects driver if needed. DOUT1 is controlled by scenario for user needs, to manage buzzer, LED etc.

**Authorized Driving Scenario.** Gives ability to use vehicle only for 50 specific iButton owners (specified in iButton list). DOUT2 is controlled by scenario for user needs, to manage buzzer, LED etc.

**Immobilizer Scenario.** Vehicle can be used only if iButton is connected. In this scenario iButton list is not used; connect any iButton to pass Immobilizer security. DOUT2 is controlled by scenario for user needs.

#### 5.4.2 Trip

Trip customizable feature enables user extended monitoring of performed trips (from engine start at present location to engine stop at arrived location), log their start and stop points, view driven total distance. Event will be **generated (included into send records) only** when trip starts and finish.

#### 5.4.3 Geofencing

Geofencing is another feature which is highly customizable and can detect wherever car enters or leaves customized areas. More about Geofencing can be read in 5.13.3 chapter.

Auto Geofencing feature if enabled is activated automatically by turning off car ignition. Next time before driving user has to disable Auto Geofencing with iButton or by turning on car ignition. In case of theft car leaves Auto Geofencing zone without authorization FM1100 device automatically sends high priority record to AVL application.

#### 5.4.4 iButton list

iButton list is used to enter authorized iButton ID codes, which are used to authenticate driver in Authorized driving and Auto Geofencing options.

## 5.5 CONFIGURATION

### 5.6 Configurator

New FM1100 module has default factory settings. Settings should be changed according to your application and your GSM operator information.

FM1100 configuration is performed via FM1100 Configurator program. FM1100 Configurator version can be downloaded from <http://avl1.teltonika.lt/downloads/FM11/>. Contact sales manager to get the latest FM1100 Configurator version. FM1100 configurator operates on Microsoft Windows OS and uses MS .Net Framework 3.5 or higher. Please ensure that MS .Net Framework 3.5 or later is installed on your PC before starting configurator. Latest MS .Net Framework version can be downloaded from official Microsoft web page.

Module configuration is performed over USB cable. Configuration process starts from starting FM1100 Configurator program and then connecting to FM1100 device via Connect button located on the top left corner of configurator. If connected successfully IMEI, Version fields which were empty, now are filled with certain numbers depending on Modem IMEI and firmware version of your device (figure below).

FM1100 has one user editable profile, which can be loaded from device, and saved. User can also revert to default settings, by pressing Load Defaults button. After any modification of configuration settings it has to be saved to FM1100 device, otherwise it will not be written to device.

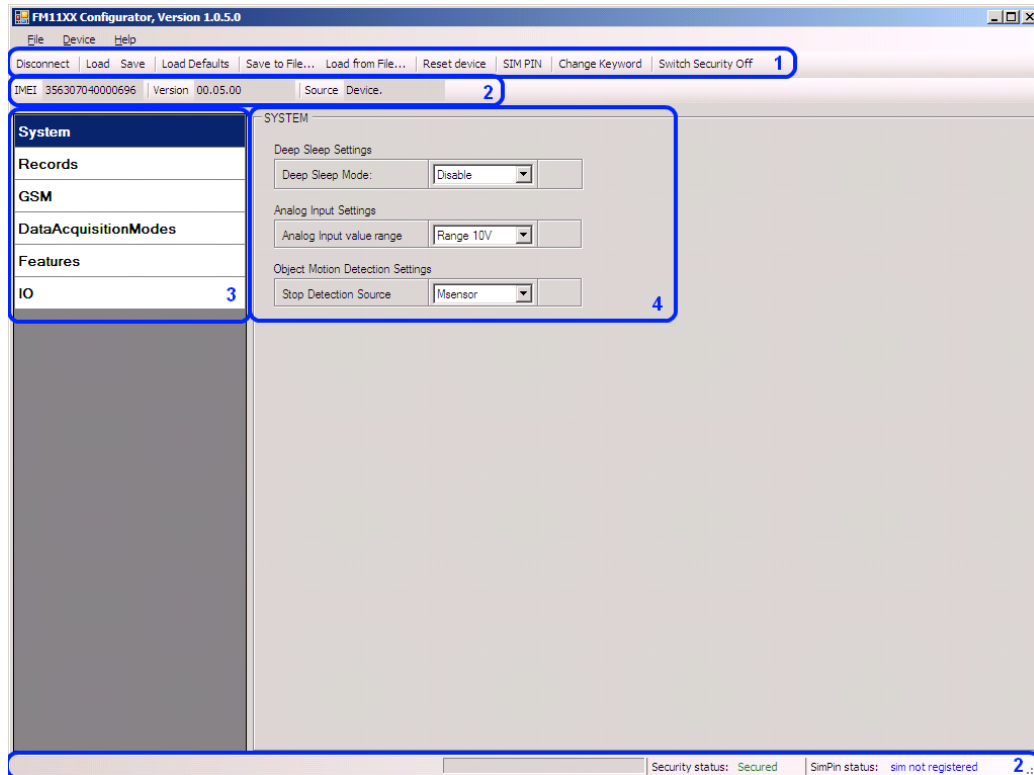

Figure 17. Configurator window

FM1100 Configurator is divided into 4 main areas: 1 – main button area, 2 – information area, 3 – settings menu, 4 – parameters and values menu.

Button description:

'Connect' – connects device

'Load' – reads configuration parameters from FM1100 Flash memory.

'Save' – saves configuration parameters to FM1100 Flash memory.

'Load Defaults' – loads default FM1100 settings that later can be modified. This procedure must be performed before entering new parameters.

'Save to File...' – allows user to save currently entered settings to .XML file, for later usage.

'Load from File...' – allows user to load configuration saved in .XML extension file.

'Reset device' – reboots FM1100 and displays processor firmware version.

Additional buttons:

'SIM PIN' – this button is used to enter PIN code if inserted SIM card has activated PIN code security.

'Add Keyword' / 'Change Keyword' / 'Switch Security Off' – buttons are used to protect configurator from unauthorized access to configuration.

Keyword is 4 -10 symbol length. If keyword is set, every time user reconnects FM2200 to USB port, user will be asked to provide valid keyword when connecting FM1100 to configurator. User is given 5 attempts to enter valid keyword. After entering valid keyword, counter resets to 5.

If user disconnects FM2200 using 'Disconnect' button and does not disconnect from USB port, after reconnecting using 'Connect' button, configurator does not ask for keyword.

## 5.7 System settings

System settings have 3 configurable parameters:

Deep sleep settings, where user can turn deep sleep on or off.

Analog Input Settings, where user can choose analog input range 10 V or 30 V, depending on needed accuracy (lower range gives higher accuracy of measurements), and input voltage.

Object Motion Detection Settings, where user can configure 3 ways how FM1100 will detect stopped movement, and change its working mode (for working modes, read section 5.12).

Stop Detection Source	Vehicle on Stop mode	Vehicle Moving mode
Ignition (recommended)	ignition (DIN1) is logic low	if ignition (DIN1) is logic high
Msensor (movement sensor)	internal movement sensor does not detect movement	internal movement sensor detects movement
GPS	GPS fix is available and vehicle speed is lower than 5 km/h	GPS fix is available and vehicle speed is higher than 5 km/h
	while GPS fix is unavailable, Object Motion Detection Settings is working like previously mentioned Msensor mode	
Static Navigation Mode	This is a filter, which filters out track jumps when the object is stationary.	

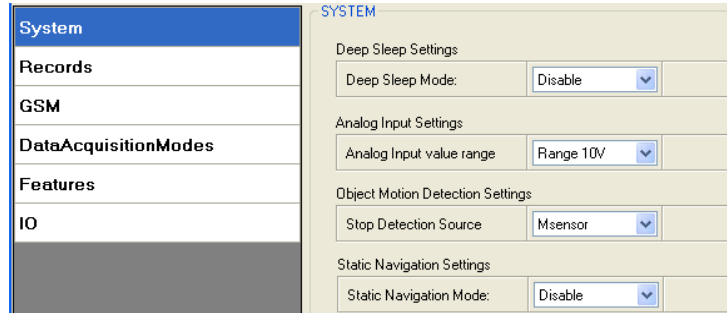

Figure 18. System settings configuration

### 5.8 Records settings

Here user can modify if FM1100 device will send newest records first, meaning, that the most important thing is to know recent position of car, older records are being sent right after newest records arrive to AVL application.

Activate Data Link Timeout is used to set timeout of link between FM1100 and AVL application termination. If FM1100 already sent all records it waits for new records before closing link. If new records are generated in the period of this timeout, and minimum count to send is reached, they are send to AVL application. This option is useful in conditions where GSM operators put charge on every link activation.

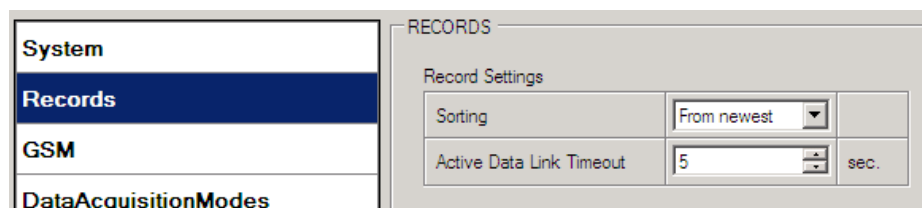

Figure 19. Records settings configuration

### 5.9 GSM settings, GPRS part

'GPRS' define main parameters for FM1100: GSM operator APN and GPRS username and password (optional – depending on operator), destination server IP and port, and allows to set protocol used for data transfers – TCP or UDP

Some operators use specific authentication for GPRS session – CHAP or PAP. If any of these is used, APN should be entered as '<APN>:c' or '<APN>:p'. I.e. if operator is using APN 'internet' with CHAP authentication, it should be entered as 'internet:c'. Information about APN and authentication type should be provided by your GSM operator.

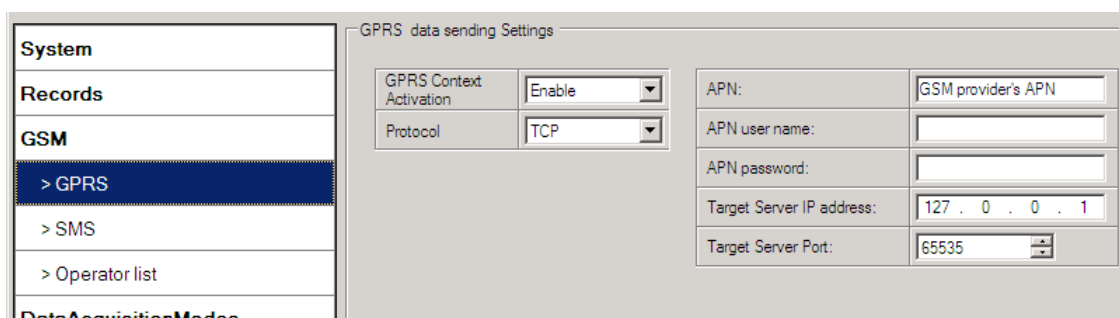

Figure 20. GPRS configuration

### 5.10 GSM settings, SMS part

Essential fields in 'SMS' part is 'Login' and 'Password'. This login and password is used with every SMS sent to FM1100. If login and password is not set, in every SMS send to FM1100 device two spaces before command has to be used (<space><space><command>).

Command structure with set login and password:

<login><space><password><space><command>, example: "asd 123 getgps"

Phone numbers has to be written in international standard, without using "+" or "00" signs in prefix. If none numbers are entered, configuration and sending commands over SMS are allowed from all GSM numbers.

SMS data sending settings – enable or disable **periodic** data and event SMS usage. This setting does not affect replies to SMS request messages – answers are always sent back to sender telephone number.

FM1100 can send SMS with 24-coordinates-in-one-SMS, it is used in areas where no GPRS coverage is available. Module collects data and sends to server binary SMS containing information about last 24 collected points. SMS sending schedule is set in SMS Week Time tab. 24-Coordinates SMS decoding is described in "FMXXXX Protocols" document.

Figure 21. SMS configuration



SMS login and password and authorized number list are used to protect FM1100 module from unauthorized access. Module accepts messages only from a list of authorized numbers and with proper module login and password. Numbers must be without "+" or "00" prefix. If no authorized numbers are entered, module accepts messages from all numbers.

### 5.11 GSM settings, Operator list

Operators list – FM1100 is able to use GPRS with all operators, but if at least one operator is entered in the list, FM1100 is allowed to connect to GPRS only while operating in listed operator's network.

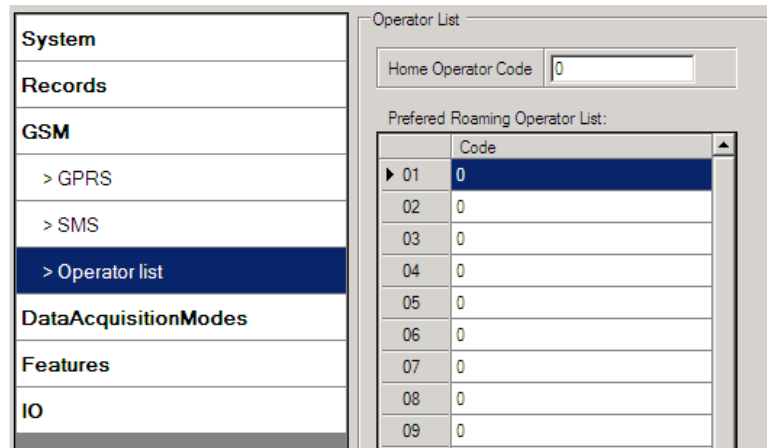

Figure 22. Operator list configuration

### 5.12 Data Acquisition Mode settings

Data Acquisition Modes are essential part of FM1100 device, it is also highly configurable.

By configuration user defines how records will be saved and sent. There are three different modes: Home, Roaming and Unknown. All these modes with configured data acquisition and send frequencies depend on current GSM Operator defined in Operator list (see section 5.11) and are being switched when GSM operator changes (e.g. vehicle passes through country boarder).

If current GSM operator is defined as Home Operator, device will work in Home Data Acquisition mode, if current operator is defined as Roaming Operator, device will work in Roaming Data Acquisition mode, and if current operator code is not written in Operator list (but there is at least one operator code in the operator list), device will work in Unknown Acquisition mode.

This functionality allows having different AVL records acquire and send parameters values when object is moving or stands still. Vehicle moving or stop state is defined by Stop Detection Source parameter. There are 3 ways for FM1100 to switch between Vehicle on Stop and Vehicle Moving modes see section 5.7.

As result, FM1100 allows to have 6 different modes. Operational logic is shown Figure .



If there are no operator codes entered into operator list, FM1100 will work in Unknown network mode.

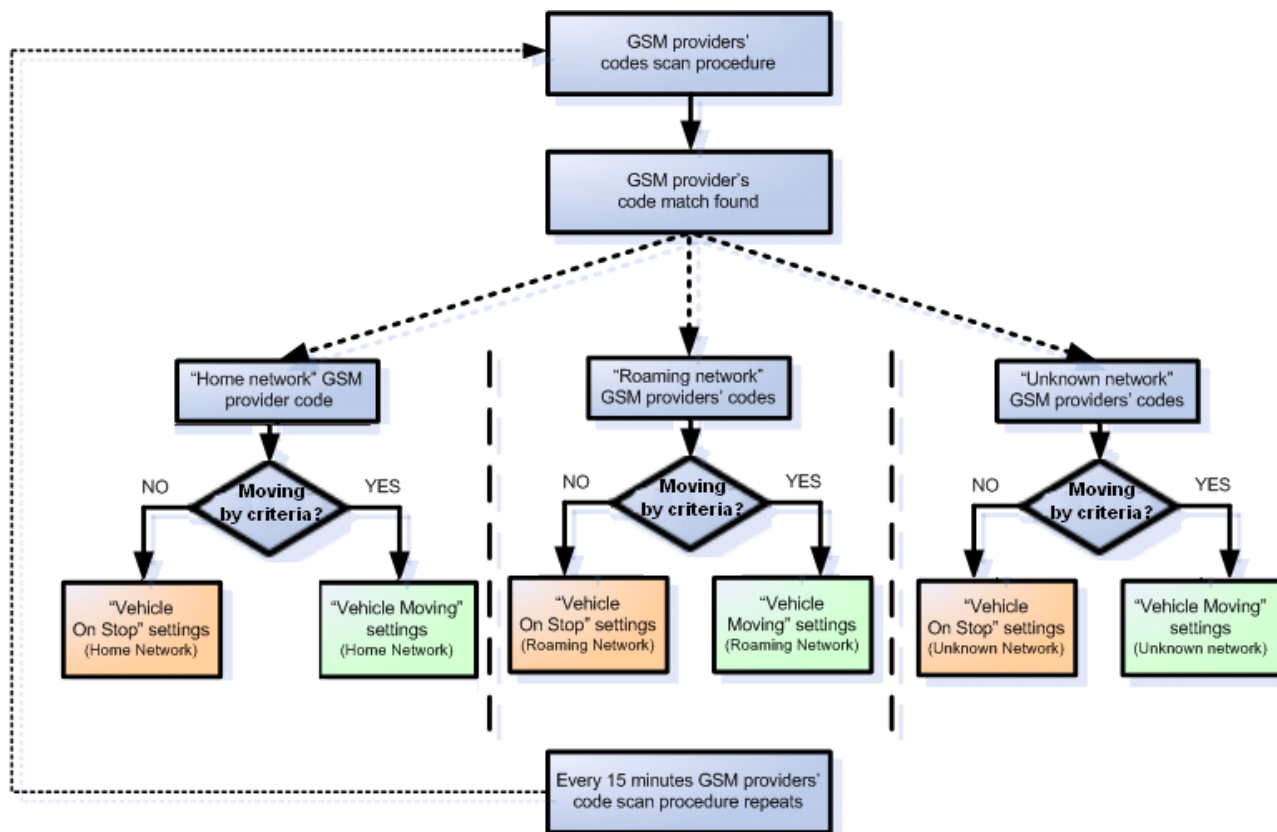

**Figure 23. Data Acquisition Mode configuration**

Operator search is performed every 15 minutes. Depending on current GSM operator, Home, Roaming or Unknown mode can be changed faster than every 15 minutes. This process is separate from operator search. Movement criteria are checked every second.

<b>System</b> <b>Records</b> <b>GSM</b> <b>DataAcquisitionModes</b> > Home > Roaming > Unknow <b>Features</b>	Data Acquisition Modes : Home					
	Vehicle on STOP		Vechicle MOVING			
	Min Period:	600	sec.	Min Period:	600	sec.
				Min Distance:	1000	m.
				Min Angle:	30	deg.
Min Saved Records:	20		Min Saved Records:	20		
Send Period:	600	sec.	Send Period:	600	sec.	
	GPRS Week Time		GPRS Week Time			

**Figure 24. Data Acquisition Mode configuration**

'Min Saved Records' defines minimum number of coordinates and I/O data that should be transferred with one connection to server. If FM1100 does not have enough coordinates to send to server, it will check again after time interval defined in 'Sending Period'

Send period – GPRS data sending to server period. Module makes attempts to send collected data to server every defined period. If it does not have enough records (depends on parameter Min. Saved Records described above), it tries again after defined time interval.

GPRS Week Time tab – most GSM billing systems charge number of bytes (kilobytes) transmitted per session. During the session, FM1100 makes connection and transmits data to a server. FM1100 tries to handle session as much as possible; it never closes session by itself. Session can last hours, days, weeks or session can be closed after every connection in certain GSM networks – this depends on GSM network provider. GPRS Context Week Time defines session re-establish schedule if session was closed by network. New GPRS context is opened if time is 10 minutes till time checked in table. Therefore if all boxes are checked, FM1100 is able to open new connection anytime. At scheduled time match FM1100 checks for GPRS session activity. If GPRS session is alive, FM1100 sends data to server according to Send period parameter. If it is not, FM1100 checks if it is able to re-establish the session.

Device is checking if the time between last saved record and current time is equal or higher than Time based acquire interval. If so, FM saves record to memory. If not, FM checks if the distance from last record to current record is equal or higher than Distance based acquire interval. If so, saves the record to memory. If not and speed is higher than 10km/h, then FM is checking if angle difference between last record and current record is equal or higher than Angle based acquire value. If so, saves the record to memory. This check is being performed every second.

FM1100 is able to collect records using three methods at the same time: time, distance and angle based data acquisition:

Time based data acquiring (Min. period) – records are being acquired every time when defined interval of time passes. Entering zero disables data acquisition depending on time.

Distance based data acquiring (Min. distance) – records are being acquired when the distance between previous coordinate and current position is greater than defined parameter value. Entering zero disables data acquisition depending on distance.

Angle based data acquiring (Min. angle) – records are being acquired when angle difference between last recorded coordinate and current position is greater than defined value. Entering zero disables data acquisition depending on angle.

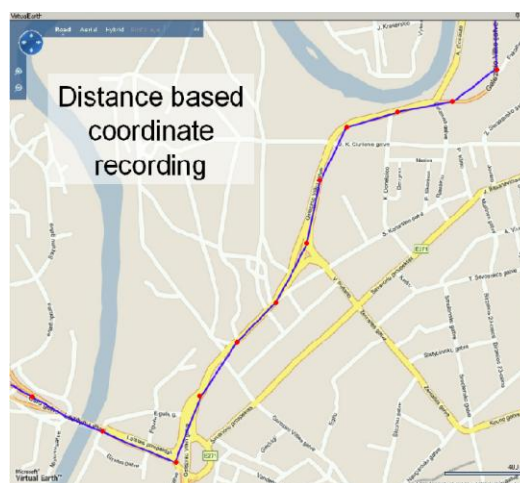
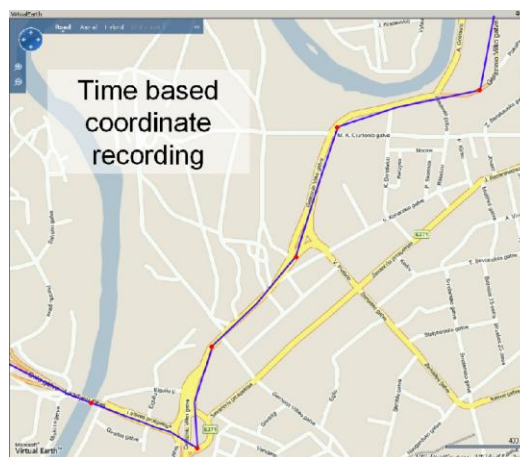

### 5.13 Features settings

For more information about available Scenarios, Trip, Geofencing and iButton list, refer to 5.4 chapter.

### 5.13.1 Scenarios settings

In Scenarios window four different scenarios are available, two per each Digital Output (DOUT). Only one per digital output can be active at a same time, e.g. DOUT1 can have either Green driving or Over Speeding enabled, DOUT2 can have either Authorized Driving or Immobilizer enabled.

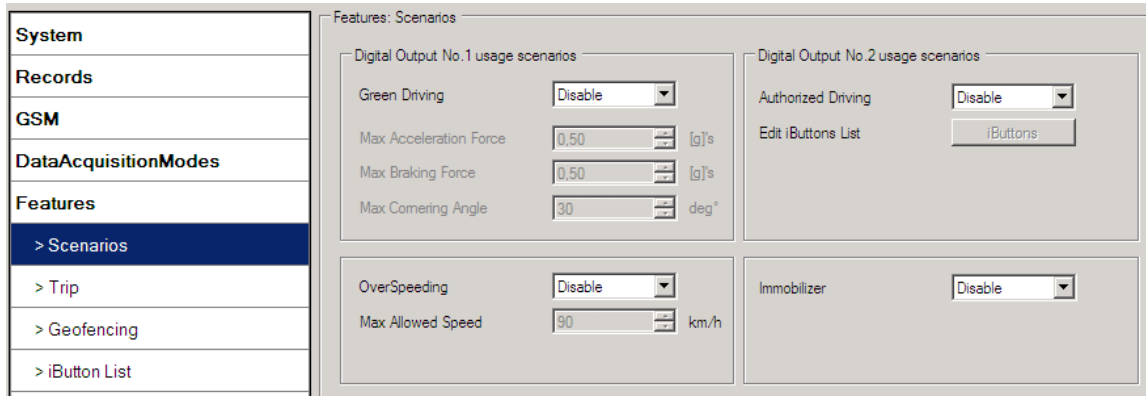

**Figure 25. Scenarios configuration**

Digital Output (open drain grade) usage in scenarios:

- **Green Driving**  
DOUT1 is ON for:
  - 3sec. if detected value is over (0; 30] % from preconfigured allowed value
  - 5sec. if detected value is over (30; 50] % from preconfigured allowed value
  - 7sec. if detected value is over (50; -] % from preconfigured allowed value
 After period of time DOUT1 is turned OFF.
- **Over Speeding**  
DOUT1 is ON and blinking with 300 ms duty cycle. While vehicle speed exceeds parameter value DOUT1 is activated until current speed is not decreased below parameter value.
- **Authorized driving**  
DOUT2 is ON continuously. After authorizing iButton, DOUT2 turns off. After successful authorization DIN1 (ignition) can be turned OFF for no longer than 30 seconds, otherwise authorization must be repeated.
- **Immobilizer**  
DOUT2 is ON continuously, after 1 minute blinks with 300 ms duty cycle if iButton is not connected. DOUT2 turns OFF, after iButton is connected. After successful deactivation of immobilizer DIN1 (ignition) can be turned OFF for no longer than 30 seconds, otherwise Immobilizer security will be turned on and deactivation must be repeated.

### 5.13.2 Trip settings

Trip window offers user to configure Trip feature. If Trip is enabled configuration of parameters are enabled.

Start Speed – speed, which is detected as minimum speed to indicate Trip start.

Ignition Off Timeout – timeout to wait if ignition was off, to detect Trip stop.

Continuous distance counting – Not or Continuous can be chosen. For this feature I/O Odometer must be enabled (see Figure )

If I/O Odometer is enabled and Continuous distance counting variable is set to Continuous, Trip distance is going to be counted continuously (from Trip start to Trip stop). This value is written to I/O Odometer value field. When Trip is over and next Trip begins, Odometer value is reset to zero, and is counted continuously again.

If I/O Odometer is enabled and Continuous Distance Counting variable is set to Not, then distance is going to be counted only between every record made. This value is written to I/O Odometer value field and reset to zero every new record until Trip stops. If later all Odometer values are summed up manually user gets distance driven over whole Trip period.

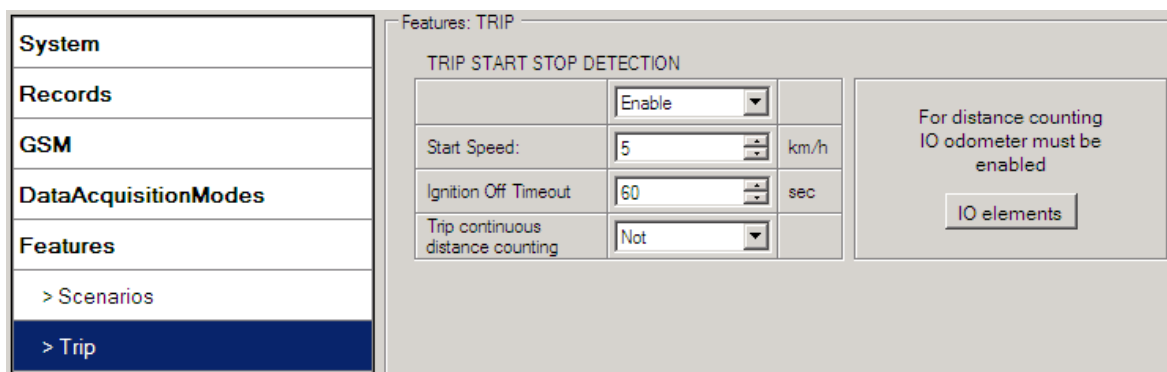

Figure 26. Trip configuration

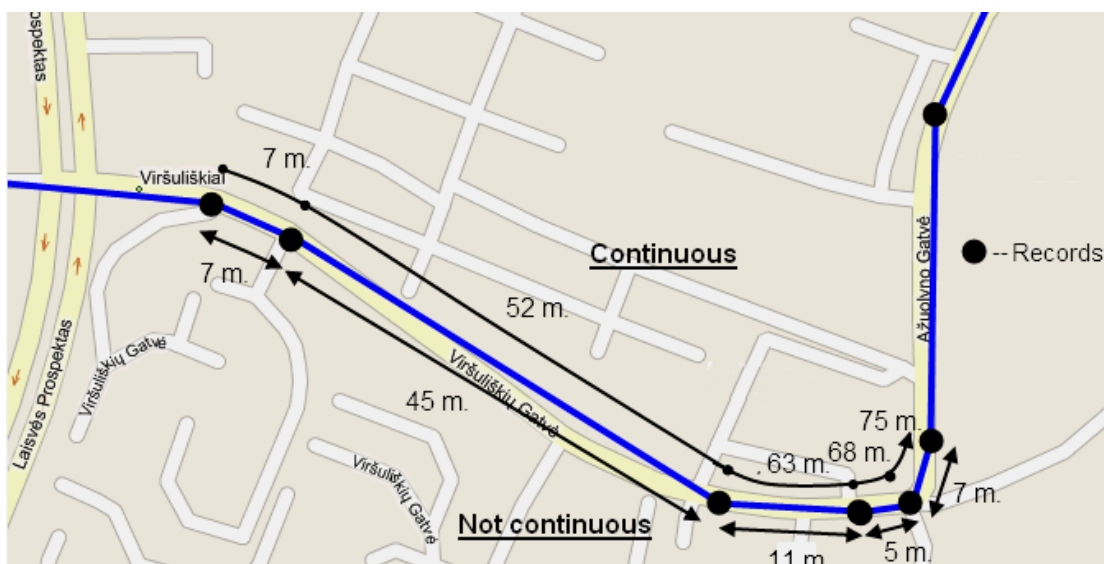

Figure 27. Trip continuous distance counting parameter example

### 5.13.3 Geofencing settings

#### Geofencing settings

FM1100 has 5 configurable Geofence zones and it can generate event when defined Geofence zone border is crossed.

Frame border – frame border is an additional border around Geofence zone. It is additional area around defined zone used to prevent false event recording when object stops on the border of the area and because of GPS errors some records are made inside area and some – outside. Event is generated only when both borders are crossed. See figure for details: track 1 is considered to enter the area while track 2 does not.

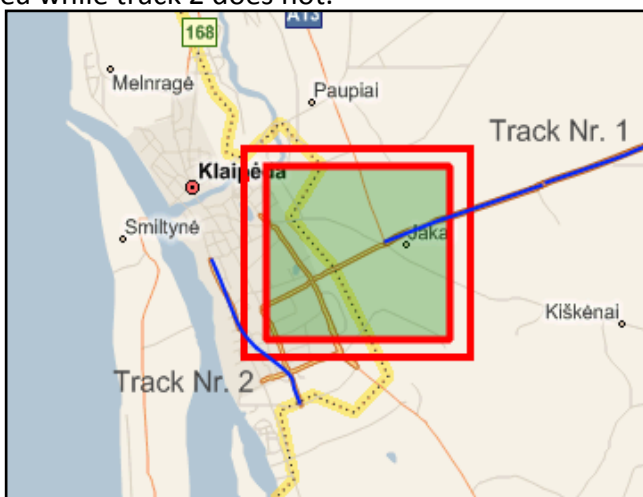

Figure 28. Geofence border

Shape – can be rectangular or circle

Priority – priority of Geofence event: low, high or panic. These levels define priority of event information sending to server. See I/O element description for more details about priorities.

Generate event (On entrance, On exit, On Both) – choose when record will be generated;

X1 – geofence zone left bottom corner X coordinate;

Y1 – geofence zone left bottom corner Y coordinate;

X2 or R – geofence zone upper right corner X coordinate (radius of circle when Circular zone used);

Y2 – geofence zone upper right corner Y coordinate;

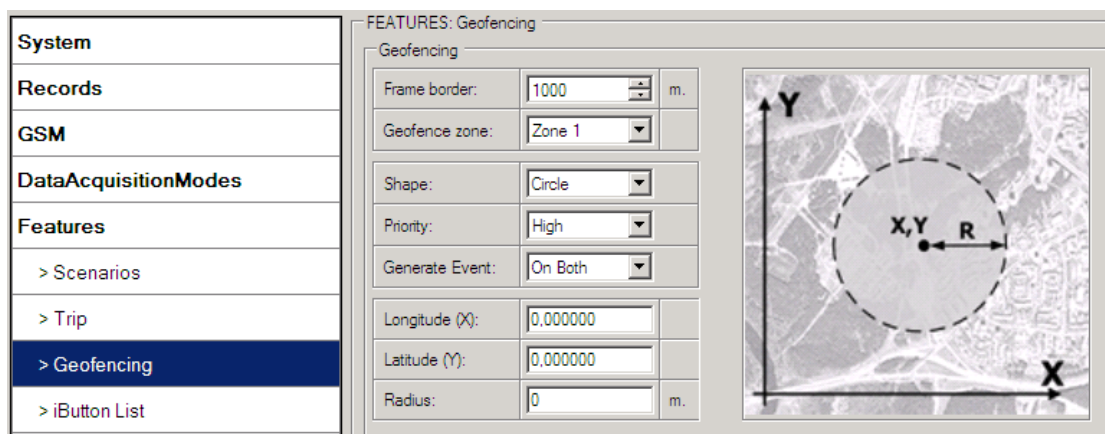

Figure 29. Geofence configuration

### AutoGeofencing settings

*“AutoGeofence – the last known position after movement = off. If your car’s being taken away – you can be notified. The shape and size of the geofence zones are parameters. Possibility to state whether entering in or out of the geofence triggers an asynchronous message.”*

Auto Geofencing option can be configured by following parameters visible in figure below.

Activate – Enable or Disable Autogeofence functionality

Activation TMO – Time period before Geofence is activated after vehicle stops.

Deactivate By –

Ignition – If ignition becomes high it will drop AutoGeofence Zone

iButton – if iButton is attached it will drop AutoGeofence Zone

Edit iButton List – if list is not empty attached iButton is tested against a iButton list, if match is found AutoGeofence zone is dropped.

Priority – Priority of generated event, which will be applied to saved record.

Enter Event – Event generation on Geofence entrance.

Exit Event – Event generation on Geofence exit.

On Both - Event generation on Geofence entrance Or exit

Note, that Auto Geofencing does not require entering coordinates, instead it requires GPS visibility. If vehicle stopped and activation timeout is passed, Auto Geofence will be created around vehicle last position by set Radius value. Auto Geofence event generation works the same as Geofencing mentioned above.

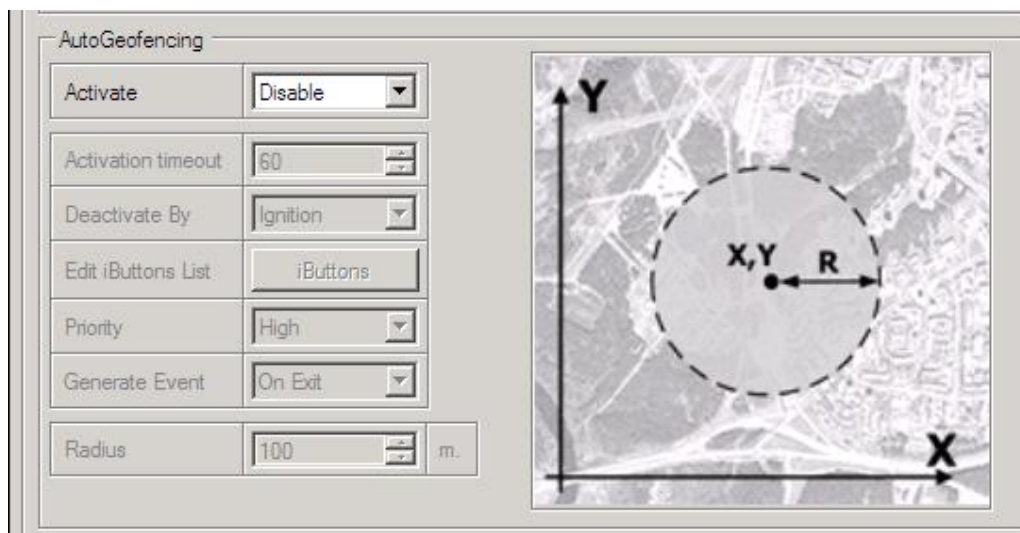

Figure 30. Geofence configuration



Note FM1100 operates GMT time without daylight saving.

## 5.14 I/O settings

When no I/O element is enabled, AVL packet comes with GPS information only. After enabling I/O element(s) AVL packet in couple with GPS information contains current value(s) of enabled I/O element.

Permanent IO elements (are always sent to server if enabled)			
Property ID	Property Name	Bytes	Description
1	Digital Input Status 1	1	Logic: 0 / 1
2	Digital Input Status 2	1	Logic: 0 / 1
3	Digital Input Status 3	1	Logic: 0 / 1
9	Analog Input 1	2	Voltage: mV, 0 – 30 V
21	GSM signal level	1	Value in scale 1 – 5
24	Speedometer	2	Value in km/h, 0 – xxx km/h
66	External Power Voltage	2	Voltage: mV, 0 – 30 V
72	Dallas Temperature	4	10 * Degrees ( °C ), -55 - +115, if 3000 – Dallas error
78	iButton Input	8	iButton ID number
80	Working mode	1	0 – home on stop, 1 – home on move, 2 – roaming on stop, 3 – roaming on move, 4 – unknown on stop, 5 – unknown on move
179	Digital output 1 state	1	Logic: 0 / 1
180	Digital output 2 state	1	Logic: 0 / 1
181	PDOP	2	Probability * 10; 0-500
182	HDOP	2	Probability * 10; 0-500
199	Virtual Odometer	4	Distance between two records: m
200	Deep Sleep	1	0 – not deep sleep mode, 1 – deep sleep mode
205	Cell ID	2	GSM base station ID
206	Area Code	2	Location Area code (LAC), it depends on GSM operator. It provides unique number which assigned to a set of base GSM stations. Max value: 65536
240	Movement	1	0 – not moving, 1 – moving.
241	Current Operator Code	4	Currently used GSM Operator code
Eventual IO elements (generate and send record to server only if appropriate conditions are met)			
Property ID	Property Name	Bytes	Description
155	Geofence zone 01	1	Event: 0 – target left zone, 1 – target entered zone
156	Geofence zone 02	1	Event: 0 – target left zone, 1 – target entered zone
157	Geofence zone 03	1	Event: 0 – target left zone, 1 – target entered zone

158	Geofence zone 04	1	Event: 0 – target left zone, 1 – target entered zone
159	Geofence zone 05	1	Event: 0 – target left zone, 1 – target entered zone
175	Auto Geofence	1	Event: 0 – target left zone, 1 – target entered zone
250	Trip	1	1 – trip start, 0 – trip stop
251	Immobilizer	1	1 – iButton connected
252	Authorized driving	1	1 – authorized iButton connected
253	Green driving type	1	1 – harsh acceleration, 2 – harsh braking, 3 - harsh cornering
254	Green driving value	2	Depending on green driving type: if harsh acceleration or braking – $g \cdot 100 \text{ m/s}^2$ , if harsh cornering – degrees
255	Over Speeding	2	At over speeding start km/h, at over speeding end km/h



There are two types of operations with Permanent I/O elements: simple monitoring and event generating. Monitoring method is used when current I/O information needed with regular GPS coordinates. Event generating method is used when additional AVL packet is needed when current value of I/O exceeds predefined High and Low levels. I/O settings allow defining I/O event criteria.

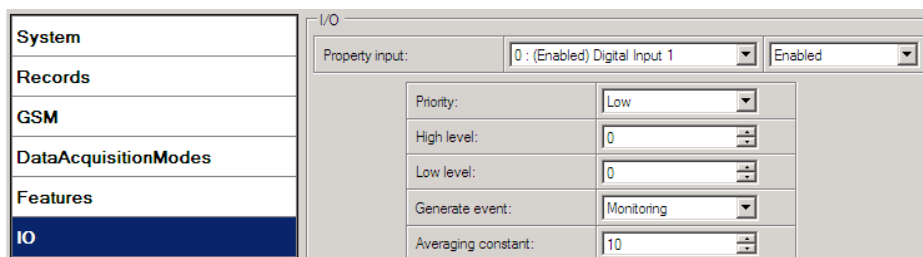

Figure 31. I/O settings

Enabled or disabled field – allows enabling I/O element so it is added to the data packet and is sent to the server. By default all I/O element are disabled and FM1100 records only GPS coordinates.

Priority – AVL packet priority – low, high or panic. Regular packets are sent as Low priority records. When low priority event is triggered, FM1100 makes additional record with indication that the reason for that was I/O element change. When High priority is selected, module makes additional record with high priority flag and sends event packet immediately to the server by GPRS. Panic priority triggers same actions as high priority, but if GPRS fails, it sends AVL packet using SMS mode if SMS is **enabled in SMS settings**.

High and Low levels – define I/O value range. If I/O value enters or exits this range, FM1100 generates event. “Generate event” parameter defines when to generate event – when value enters defined range, exits it or both.

Averaging constant – it is an I/O event delay parameter. In some applications there is no need to generate events on every I/O range enter/exit immediately. Sometimes it is necessary to wait some time interval before event generating. Averaging constant allows setting I/O event

delay (averaging). If I/O value is entering or leaving predefined range, it must have same value for Averaging constant time. 1 Averaging constant value equals 1 second. There is no Averaging on DIN1, and in Deep Sleep mode.

### 5.14.1 Monitoring

I/O monitoring starts after enabling I/O element and setting up I/O parameters as it is shown below:

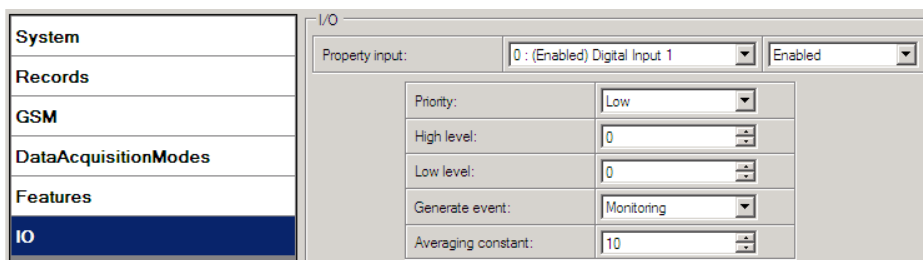

Figure 32. I/O settings

### 5.14.2 Event Generating

Events happen when the value of enabled I/O intersects thresholds (enter, exit or on both) predefined by High and Low level thresholds. Table below defines all available values of I/O settings.

Priority	low, high
High level	maximum threshold
Low level	minimum threshold
Generate event	on interval enter, on interval exit, on both enter and exit
Average constant	$1 - 2^{32}$ (4 Bytes)

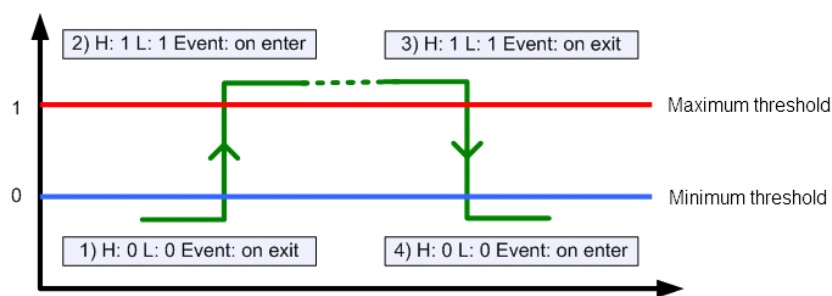

Figure 9. Digital Input event generation example

## 5.14.3 Hysteresis

Priority:	Low
High level:	0
Low level:	0
Generate event:	Hysteresis
Averaging constant:	10

I/O elements can generate events according to hysteresis algorithm. If I/O event operand "Hysteresis" is selected, events will be generated as it is shown in the illustration below:

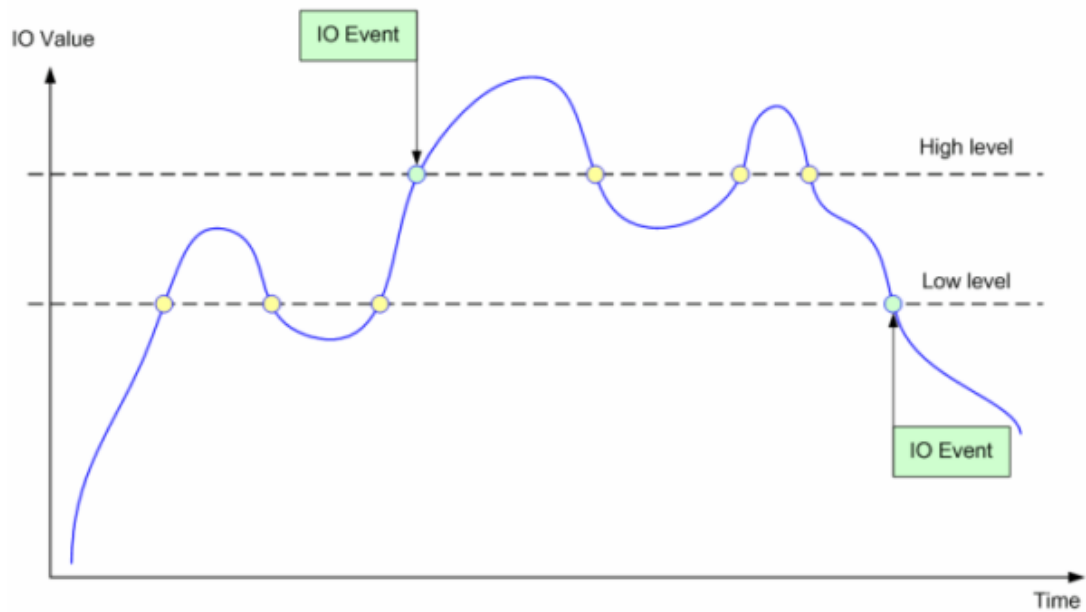

Figure 104. Event generation according hysteresis algorithm

## 6 SMS COMMAND LIST

Read chapter 5.10 to know how to construct proper SMS message and send it to FM1100 device. All commands are case sensitive. While FM1100 operates in Deep Sleep mode and user tries to send SMS message it could not arrive to FM1100 device, because GSM/GPRS module is disabled most of the time (wake up depends on Send Period parameter). It is recommended to wait until FM1100 is not in Deep Sleep mode.

### 6.1 SMS command list

Command	Description	Response
getstatus	Modem Status information	Yes
getweektime	Current device time, Day of Week and amount of minutes passed since start of week	Yes
getops	List of currently available GSM operator	Yes
getcfgtime	Date and Time of last successful configuration	Yes
getgps	Current GPS data and time	Yes
cpureset	Reset CPU	No
resetprof	Reset all FLASH1 profile to default profile	No
getver	Device / Modem / Code version information	Yes
getinfo	Device runtime system information	Yes
deleterecords	Delete all records saved on FLASH	No
getio	Readout digital inputs and outputs	Yes
readio #	Readout input value according entered ID, # - ID value	Yes
setdigout ##	set digital outputs 0 – OFF, 1 – ON DO1 DO2	Yes
getparam #	Readout parameter value according entered ID. # - ID value.	Yes
setparam # #	Set parameter value according entered ID and Value. 1.# - ID value. 2.# - New Parameter Value	Yes
flush #,#,#,#,#,#,#	Initiates all data sending to specified target server 1.# - IMEI 2.# - APN 3.# - LOGIN 4.# - PASS 5.# - IP 6.# - PORT 7.# - MODE (0-TCP/1-UDP)	No

### 6.1.1 getstatus

Response details	Description
Data Link	Indicate module connection to server at the moment: 0 – Not connected, 1 – connected
GPRS	Indicate if GPRS is available at the moment
Phone	Voice Call status: 0 – ready, 1 – unavailable, 2 – unknown, 3 – ringing, 4 – call in progress, 5 – asleep
SIM	SIM Status: 0-ready, 1-pin, 2-puk, 3-pin2, 4-puk2
OP	Connected to GSM Operator: numerical id of operator
Signal	GSM Signal Quality [0-5]
NewSMS	Indicate if new message received
Roaming	0 – Home Network, 1 – roaming
SMSFull	SMS storage is full? 0 – ok, 1 – SMS storage full
LAC	GSM Tower Location Area Code
Cell ID	GSM Tower Cell ID Code

Example: Data Link: 0 GPRS: 1 Phone: 0 SIM: 0 OP: 24602 Signal: 5 NewSMS: 0 Roaming: 0 SMSFull: 0 LAC: 1 Cell ID: 864

### 6.1.2 getweetime

Response details	Description
Clock Sync	Indicates system clock synchronization status. 0 – System is not synchronized, 1 – System synchronized
DOW	Day Of Week – indicates current day of week starting from 0 – Monday, 1 – Tuesday, etc.
Time	Indicates current GMT time
WeekTime	Indicates time in minutes starting from Monday 00:00 GMT

Example: Clock Sync: 1 DOW: 4 Time 12:58 Weektime: 6538

### 6.1.3 getops

Response details	Description
LIST	Returns list of current available allowed operators.

Example: GSM OP LIST: 0. 24602

### 6.1.4 getcfgtime

Response details	Description
Date/Time	Returns last performed configuration date and time.

Example: Last Configuration was performed on: 2010.4.15 5:45:19

### 6.1.5 getgps

Response details	Description
GPS	Indicates valid (1) or invalid (0) GPS data
Sat	Count of currently available satellites
Lat	Latitude (Last good Latitude)
Long	Longitude (Last good Longitude)
Alt	Altitude
Speed	Ground speed, km/h
Dir	Ground direction, degrees
Date	Current date
Time	Current GMT time

Example: GPS:1 Sat:7 Lat:54.71473 Long:25.30304 Alt:147 Speed:0 Dir:77 Date: 2007/8/24  
Time: 13:4:36

### 6.1.6 getver

Response details	Description
Code Ver	Firmware version
Device IMEI	IMEI
Device ID	Device ID is used to detect by server which type of configuration to load
Bootloader Ver	Bootloader Version
Modem App Ver	Version of modem application (veiks: nuo 00.05.14)

Example: Code Ver:0.48.17 Device IMEI:353976010139156 Device ID:000001 Bootloader Ver: 01.06 Modem APP Ver:01.00.02

### 6.1.7 getinfo

Response details	Description
INI	Device Initialization Time
RTC	RTC Time
RST	Restart Counter
ERR	Error Counter
SR	Number of Sent Records
BR	Number of broken records
CF	Profile CRC Fail counter
FG	Failed GPRS counter
FL	Failed link counter
UT	UPD Timeout counter
SMS	Sent SMS Counter
NOGPS	No GPS Timer
GPS	GPS receiver state. 0 – OFF, 1 – restarting, 2 – ON but no fix, 3 – ON and operational, 4 – sleep mode
SAT	Average satellites
RS	Reset Source Identification

	1 – Low Power, 2 – W Watchdog, 3 – I Watchdog, 5 – Power On, 6 - Pin Reset
MD	Data Mode state. 0 – Home and Stop, 1 – Home and Moving, 2 – Roaming and Stop, 3 – Roaming and Moving, 4 – Unknown and Stop, 5 – Unknown and Moving

Example: INI:2007/8/24 10:15 RTC:2007/8/24 12:43 RST:2 ERR:11 SR:182 BR:0 CF:0 FG:0 FL:0 UT:0 SMS:2 NOGPS:0:0 GPS:3 SAT:7 RS:5 MD:0

#### 6.1.8 getio

Response details	Description
DI#	Digital Input state
DO#	Digital Output state

Example: DI1:0 DI2:0 DO1:0 DO2:0

#### 6.1.9 readio #

Response details	Description
ID	I/O element ID
Value	I/O Element value

Example: IO ID:3 Value:0

#### 6.1.10 setdigout ##

Sets digital outputs to ON or OFF state. Value is written as a row for OUT1 and OUT2 values.

Example: 'setdigout 01' will set OUT2 to high level, while OUT1to low level.

#### 6.1.11 getparam #####

Read parameter value. ID consists of 4 digits – first digit identifies profile, second, third and fourth identifies parameter ID as described in Parameter List chapter.

Response details	Description
ID	Profile number and parameter ID
Value	Parameter value

Example: 'getparam 1245' command will request server IP address in profile1.

#### 6.1.12 setparam ##### #

Sets new value for parameter. ID consists of 4 digits – first digit identifies profile, second, third and fourth identifies parameter ID as described in Parameter List chapter. In value field a new parameter value is entered.

Example: 'setparam 1245 127.0.0.1' will change configured IP address in profile1 with new value

### 6.1.13 flush #,#,#,#,#,#,#

Initiates all data sending by GPRS to specified target server. Comma separated parameters go as numbered:

- 1.# - IMEI
- 2.# - APN
- 3.# - GPRS LOGIN
- 4.# - GPRS PASSWORD
- 5.# - IP
- 6.# - PORT
- 7.# - MODE (0-TCP/1-UDP)

Parameters are separated by comma (no spaces needed). In case you don't need to enter parameter (Login/Pass) – do not put space, simply put comma and write next parameter.

Example: opa opa flush 353976012555151,banga,,,212.47.99.62,12050,0

Response details	Description
FLUSH SMS Accepted	FLUSH SMS Accepted
# records found on FLASH	Number of records found on FLASH
Minimum Records to Send: #	Number of minimum saved records to send
GPRS Enabled: #	State of the GPRS connection, 0 – disabled; 1 – enabled
Time Sync: #	Indicates time synchronization on the device, 0 – not synchronized; 1 – synchronized

Example: FLUSH SMS Accepted. 11 records found on FLASH. Minimum Records to Send: 1. GPRS Enabled: 1. Time Sync: 1.

## 7 Debug mode

FM1100 is able to transmit its current state when connected to PC using USB cable. It is used to detect errors and provide information to possible solutions when operating as unexpected.

Download Terminal from: <http://avl1.teltonika.lt/Downloads/Software/Terminal.zip>.

After launching terminal choose baud rate 115200 and hardware control – none. Select COM port which is assigned to “Virtual COM Port”. Click on ‘Start Log’ button and save a new file. Then click ‘Connect’ to start receiving messages from FM1100.

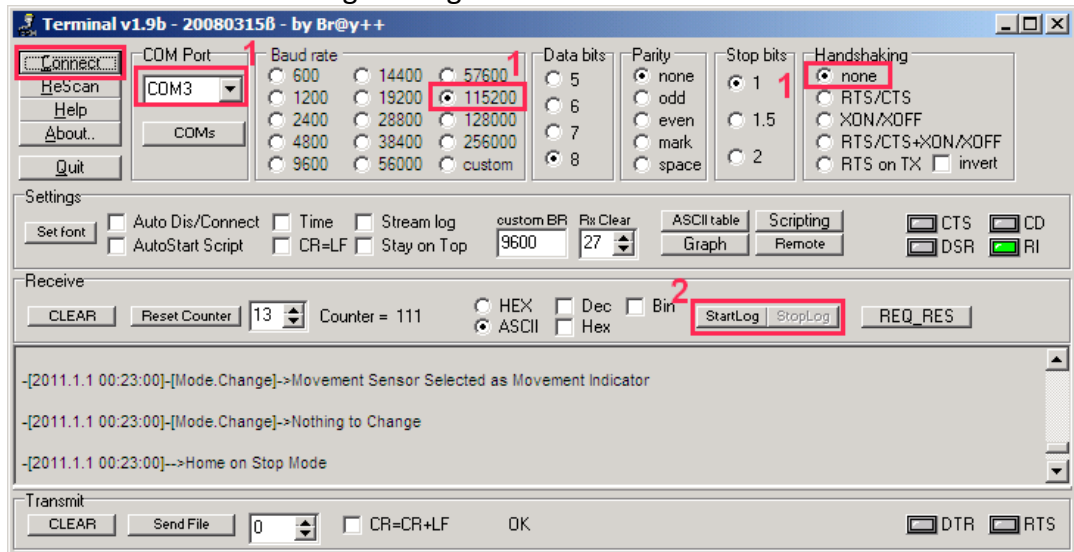

Figure 35. Terminal window

## 8 Parameter List

### 8.1 Parameters value types

- S8 – Signed Char
- S8[n] – String of  $n$  Char
- U8 – Unsigned Char
- U16 – Unsigned Short
- S32 – Signed Integer
- U32 – Unsigned Integer
- U64 – Unsigned Long Long Integer

### 8.2 System parameters

#### 8.2.1 Deep Sleep Mode (ID=1000)

Device can operate in two modes: active or deep sleep. In active mode (value 0) module is able to operate all tasks, while in deep sleep mode (value 1) module reduces level of power usage.

Minimum value	Maximum value	Recommended value	Goes with (depends on) parameters	Value type
0	1	-		U8

#### 8.2.2 Analog Input value range (ID=1001)

Analog input measuring resolution and range can be defined as 0...10V (value 0) or 0...30V (value 1).

Minimum value	Maximum value	Recommended value	Goes with (depends on) parameters	Value type
0	1	-		U8

#### 8.2.3 Stop Detection Source (ID=1002)

Device can operate and change its working mode according to motion detection source: ignition (value 0), movement sensor (value 1), GPS (value 2).

Minimum value	Maximum value	Recommended value	Goes with (depends on) parameters	Value type
0	2	-	<b>8.5 Data Acquisition Modes</b> parameters	U8

### 8.3 Records parameters

#### 8.3.1 Sorting (ID=1010)

Record sorting parameter is responsible for record sorting order. Value of 0 arranging data starting from newest, while value of 1 arranging data starting from oldest.

Minimum	Maximum	Recommended	Goes with (depends on)	Value type
---------	---------	-------------	------------------------	------------

value	value	value	parameters	
0	1	-	<b>Data Acquisition Modes parameters (Send Period)</b>	U8

### 8.3.2 Active Data Link Timeout (ID=1011)

Defines for how many seconds device will keep connection to the server after successful data transfer while waiting for a new record.

Minimum value	Maximum value	Recommended value	Goes with (depends on) parameters	Value type
5	259200	-	<b>Data Acquisition Modes parameters (Send Period)</b>	U32

## 8.4 GSM parameters

### 8.4.1 GPRS content activation (ID=1240)

Parameter allows or does not allow using GPRS. If GPRS is not allowed value is 0, if GPRS is allowed value is 1.

Minimum value	Maximum value	Recommended value	Goes with (depends on) parameters	Value type
0	1	-	<b>APN Name (ID=1242)</b> <b>APN username (ID=1243)</b> <b>APN Password (ID=1244)</b>	S8

### 8.4.2 APN Name (ID=1242)

Parameter defines GPRS Access Point Name.

Minimum value	Maximum value	Recommended value	Goes with (depends on) parameters	Value type
Empty	32 char string	-	<b>GPRS content activation (ID=1240)</b> <b>APN username (ID=1243)</b> <b>APN Password (ID=1244)</b>	S8[32]

### 8.4.3 APN username (ID=1243)

Parameter defines APN username. In case operator does not use username for login, value should be empty.

Minimum value	Maximum value	Recommended value	Goes with (depends on) parameters	Value type
Empty	30 char string	-	<b>GPRS content activation (ID=1240)</b> <b>APN Name (ID=1242)</b> <b>APN Password (ID=1244)</b>	S8[30]

### 8.4.4 APN Password (ID=1244)

Parameter defines APN password. In case operator does not use password for login, value should be empty.

Minimum value	Maximum value	Recommended value	Goes with (depends on) parameters	Value type
Empty	30 char string	-	<b>GPRS content activation (ID=1240)</b> <b>APN Name (ID=1242)</b> <b>APN username (ID=1243)</b>	S8[30]

#### 8.4.5 Target Server IP address (ID=1245)

Parameter defines AVL data destination server IP address. Example: 212.47.99.62

Minimum value	Maximum value	Recommended value	Goes with (depends on) parameters	Value type
Empty	16 char string	-	<b>GPRS content activation (ID=1240)</b> <b>Target Server IP address (ID=1245)</b>	S8[16]

#### 8.4.6 Target Server Port (ID=1246)

Parameter defines AVL data destination server port number. Example: 12050

Minimum value	Maximum value	Recommended value	Goes with (depends on) parameters	Value type
Empty	65535	-	<b>GPRS content activation (ID=1240)</b> <b>Target Server Port (ID=1246)</b>	U16

#### 8.4.7 Protocol (ID=1247)

Parameter defines GPRS data transport protocol. Module can use TCP or UDP transport protocol to send data to server. For TCP protocol value is 0, for UDP protocol value is 1.

Minimum value	Maximum value	Recommended value	Goes with (depends on) parameters	Value type
0	1	-	<b>GPRS content activation (ID=1240)</b>	U8

#### 8.4.8 SMS Login (ID=1252)

User login is used to ensure module security. Used in every SMS that is sent to device. Example: ba321

Minimum value	Maximum value	Recommended value	Goes with (depends on) parameters	Value type
Empty	5 char	-	<b>SMS Password (ID=1253)</b> <b>Server Number (8.4.12)</b>	S8[5]

#### 8.4.9 SMS Password (ID=1253)

User password is used to ensure module security. Used in every SMS that is sent to device. Example: ab123

Minimum value	Maximum value	Recommended value	Goes with (depends on) parameters	Value type
Empty	5 char	-	<b>SMS Login (ID=1252)</b>	S8[5]

			<b>Server GSM Number (8.4.12)</b>	
--	--	--	-----------------------------------	--

#### 8.4.10 SMS data sending settings (ID=1250)

Parameter allows or not sending AVL data using binary SMS. If SMS use is not allowed value is 0 and 1 if SMS use is allowed.

Minimum value	Maximum value	Recommended value	Goes with (depends on) parameters	Value type
0	1	-	<b>SMS Data send week time schedule (ID=1273)</b>	S8

#### 8.4.11 SMS Data send week time schedule (ID=1273)

Parameter defines SMS data sending according to week time schedule. This parameter is used to set data sending on selected week days and hours. Minimum time step is 10 minutes.

Example value: 7F,FF,FF,FF,FF,FF,FF,FF,FF,FF,FF,FF,FF,FF,FF,FF,FF,FF

For more information read 8.5.1.4 "Schedule parameter format".

#### 8.4.12 Authorized phone numbers (ID=1260-1269)

If at least one number is entered then only those number can send messages to device. Number must be entered without "+" or "00".

Example: 37060012346

Minimum value	Maximum value	Recommended value	Goes with (depends on) parameters	Value type
Empty	-	-		S8[17]

If SMS data sending is enabled (ID=1250) first value in a list is server GSM number. To this number the SMS with 24 coordinates is sent.

#### 8.4.13 Operator List (ID=1271)

Parameter defines operator list. According to this list module selects operating profile. GSM operator codes are comma separated. First in a list is *Home Operator Code*, then Preferred Roaming Operator Codes are written. Example: 24601, 24602, 24705...24503.

Minimum value	Maximum value	Recommended value	Goes with (depends on) parameters	Value type
Empty	-	-		U32

### 8.5 Data Acquisition Modes parameters

#### 8.5.1 Home Network GSM operator code "Vehicle on STOP" parameters

##### 8.5.1.1 Min Period (ID=1540)

This parameter indicates time interval in seconds in order to acquire new record. If value is 0 it means no records by min period will be saved.

Minimum value	Maximum value	Recommended value	Goes with (depends on) parameters	Value type
0	9999999	-		U32



			<b>Min Angle (ID=1552)</b>	
			<b>GPRS Week Time (ID=1555)</b>	

#### 8.5.2.2 Min Distance (ID=1551)

This parameter indicates distance in meters in order to acquire new record. Record is stored when the distance between previous records is greater than parameters value. If value is 0 it means no records by min distance will be saved.

Minimum value	Maximum value	Recommended value	Goes with (depends on) parameters	Value type
0	9999999	-	<b>Min Period (ID=1550)</b> <b>Min Angle (ID=1552)</b> <b>GPRS Week Time (ID=1555)</b>	U32

#### 8.5.2.3 Min Angle (ID=1552)

This parameter indicates angle in degrees in order to acquire new record. If angle difference between last recorded coordinate and current position is greater than defined value, new record is stored. This parameter is operational, when speed is higher than 10km/h. If value is 0 it means no records by min angle will be saved.

Minimum value	Maximum value	Recommended value	Goes with (depends on) parameters	Value type
0	65535	-	<b>Min Period (ID=1550)</b> <b>Min Distance (ID=1551)</b> <b>GPRS Week Time (ID=1555)</b>	U16

#### 8.5.2.4 Min Saved Records (ID=1553)

This parameter defines minimum number of records in one data packet that can be sent to server. It has higher priority than Data Send Period (ID=1554).

Minimum value	Maximum value	Recommended value	Goes with (depends on) parameters	Value type
1	25	1	<b>Min Period (ID=1550)</b> <b>Min Distance (ID=1551)</b> <b>Min Angle (ID=1552)</b> <b>GPRS Week Time (ID=1555)</b>	U8

#### 8.5.2.5 Send Period (ID=1554)

This parameter indicates frequency (time interval in seconds) of sending data to server.

Minimum value	Maximum value	Recommended value	Goes with (depends on) parameters	Value type
0	9999999	-	<b>GPRS Week Time (ID=1555)</b>	U32

#### 8.5.2.6 GPRS Week Time (ID=1555)

*Read 8.5.1.4.*

### 8.5.3 Roaming Network GSM operator code “Vehicle on STOP” parameters

#### 8.5.3.1 Min Period (ID=1560)

This parameter indicates time interval in seconds in order to acquire new record. If value is 0 it means no records by min period will be saved.

Minimum value	Maximum value	Recommended value	Goes with (depends on) parameters	Value type
0	9999999	-		U32

#### 8.5.3.2 Min Saved Records (ID=1563)

This parameter defines minimum number of records in one data packet that can be sent to server. It has higher priority than Data Send Period (ID=1564).

Minimum value	Maximum value	Recommended value	Goes with (depends on) parameters	Value type
1	25	1	<b>GPRS Week Time (ID=1565)</b>	U8

#### 8.5.3.3 Send Period (ID=1564)

This parameter indicates frequency (time interval in seconds) of sending data to server.

Minimum value	Maximum value	Recommended value	Goes with (depends on) parameters	Value type
0	9999999	-	<b>Min Saved Records (ID=1563)</b> <b>GPRS Week Time (ID=1565)</b>	U32

#### 8.5.3.4 GPRS Week Time (ID=1565)

*Read chapter 8.5.1.4.*

### 8.5.4 Roaming Network GSM operator code “Vehicle MOVING” parameters

#### 8.5.4.1 Min Period (ID=1570)

This parameter indicates time interval in seconds in order to acquire new record. If value is 0 it means no records by min period will be saved.

Minimum value	Maximum value	Recommended value	Goes with (depends on) parameters	Value type
0	9999999	-	<b>Min Distance (ID=1571)</b> <b>Min Angle (ID=1572)</b> <b>GPRS Week Time (ID=1575)</b>	U32

#### 8.5.4.2 Min Distance (ID=1571)

This parameter indicates distance in meters in order to acquire new record. Record is stored when the distance between previous records is greater than parameter’s value. If value is 0 it means no records by min distance will be saved.

Minimum value	Maximum value	Recommended value	Goes with (depends on) parameters	Value type
0	9999999	-	<b>Min Period (ID=1570)</b> <b>Min Angle (ID=1572)</b> <b>GPRS Week Time (ID=1575)</b>	U32

#### 8.5.4.3 Min Angle (ID=1572)

This parameter indicates angle in degrees in order to acquire new record. If angle difference between last recorded coordinate and current position is greater than defined value, new record is stored. This parameter is operational, when speed is higher than 10km/h. If value is 0 it means no records by min angle will be saved.

Minimum value	Maximum value	Recommended value	Goes with (depends on) parameters	Value type
0	65535	-	<b>Min Period (ID=1570)</b> <b>Min Angle (ID=1572)</b> <b>GPRS Week Time (ID=1575)</b>	U16

#### 8.5.4.4 Min Saved Records (ID=1573)

This parameter defines minimum number of records in one data packet that can be sent to server. It has higher priority than Data Send Period (ID=1574).

Minimum value	Maximum value	Recommended value	Goes with (depends on) parameters	Value type
1	25	1	<b>Min Period (ID=1570)</b> <b>Min Distance (ID=1571)</b> <b>Min Angle (ID=1572)</b> <b>GPRS Week Time (ID=1575)</b>	U8

#### 8.5.4.5 Send Period (ID=1574)

This parameter indicates frequency (time interval in seconds) of sending data to server.

Minimum value	Maximum value	Recommended value	Goes with (depends on) parameters	Value type
0	9999999	-	<b>Min Saved Records (ID=1573)</b> <b>GPRS Week Time (ID=1575)</b>	U32

#### 8.5.4.6 GPRS Week Time (ID=1575)

*Read chapter 8.5.1.4.*

### 8.5.5 **Unknown** Network GSM operator code "Vehicle on STOP" parameters

#### 8.5.5.1 Min Period (ID=1580)

This parameter indicates time interval in seconds in order to acquire new record. If value is 0 it means no records by min period will be saved.

Minimum value	Maximum value	Recommended value	Goes with (depends on) parameters	Value type
0	9999999	-		U32

#### 8.5.5.2 Min Saved Records (ID=1583)

This parameter defines minimum number of records in one data packet that can be sent to server. It has higher priority than Data Send Period (ID=1584).

Minimum value	Maximum value	Recommended value	Goes with (depends on) parameters	Value type
1	25	1	<b>GPRS Week Time (ID=1585)</b>	U8

#### 8.5.5.3 Send Period (ID=1584)

This parameter indicates frequency (time interval in seconds) of sending data to server.

Minimum value	Maximum value	Recommended value	Goes with (depends on) parameters	Value type
0	9999999	-	<b>Min Saved Records (ID=1583)</b> <b>GPRS Week Time (ID=1585)</b>	U32

#### 8.5.5.4 GPRS Week Time (ID=1585)

*Read chapter 8.5.1.4.*

### 8.5.6 **Unknown** Network GSM operator code "Vehicle MOVING" parameters

#### 8.5.6.1 Min Period (ID=1590)

This parameter indicates time interval in seconds in order to acquire new record. If value is 0 it means no records by min period will be saved.

Minimum value	Maximum value	Recommended value	Goes with (depends on) parameters	Value type
0	9999999	-	<b>Min Distance (ID=1571)</b> <b>Min Angle (ID=1572)</b> <b>GPRS Week Time (ID=1575)</b>	U32

#### 8.5.6.2 Min Distance (ID=1591)

This parameter indicates distance in meters in order to acquire new record. Record is stored when the distance between previous records is greater than parameter's value. If value is 0 it means no records by min distance will be saved.

Minimum value	Maximum value	Recommended value	Goes with (depends on) parameters	Value type
0	9999999	-	<b>Min Period (ID=1570)</b> <b>Min Angle (ID=1572)</b> <b>GPRS Week Time (ID=1575)</b>	U32

#### 8.5.6.3 Min Angle (ID=1592)

This parameter indicates angle in degrees in order to acquire new record. If angle difference between last recorded coordinate and current position is greater than defined value, new record is stored. This parameter is operational, when speed is higher than 10km/h. If value is 0 it means no records by min angle will be saved.

Minimum value	Maximum value	Recommended value	Goes with (depends on) parameters	Value type
0	65535	-	<b>Min Period (ID=1570)</b> <b>Min Angle (ID=1572)</b> <b>GPRS Week Time (ID=1575)</b>	U16

#### 8.5.6.4 Min Saved Records (ID=1593)

This parameter defines minimum number of records in one data packet that can be sent to server. It has higher priority than Data Send Period (ID=1594).

Minimum value	Maximum value	Recommended value	Goes with (depends on) parameters	Value type
1	25	1	<b>Min Period (ID=1590)</b> <b>Min Distance (ID=1591)</b> <b>Min Angle (ID=1592)</b> <b>GPRS Week Time (ID=1595)</b>	U8

#### 8.5.6.5 Send Period (ID=1594)

This parameter indicates frequency (time interval in seconds) of sending data to server. In order to send data to server GPRS parameters must be enabled

Minimum value	Maximum value	Recommended value	Goes with (depends on) parameters	Value type
0	9999999	-	<b>Min Saved Records (ID=1593)</b> <b>GPRS Week Time (ID=1595)</b>	U32

#### 8.5.6.6 GPRS Week Time (ID=1595)

*Read chapter 8.5.1.4.*

### 8.6 Features Parameters

#### 8.6.1 Digital Output No.1 usage scenarios (ID=1600)

Device can operate in its scenario according to selected value: No Scenario for Digital No.1 selected (value 0); Green Driving selected (value 1), Overspeeding selected (value 2).

Minimum value	Maximum value	Recommended value	Goes with (depends on) parameters	Value type
0	2	-		U8

#### 8.6.1 Max Acceleration Force (ID=1602)

It is max allowed acceleration force which can be reached while accelerating without triggering harsh acceleration event.

Minimum value	Maximum value	Recommended value	Goes with (depends on) parameters	Value type
0.25	0.85	0.25	<b>Digital Output No.1 usage scenarios (ID=1600)</b>	Float

#### 8.6.2 Max Braking Force (ID=1603)

It is max allowed braking force which can be reached while braking without triggering harsh braking event.

Minimum value	Maximum value	Recommended value	Goes with (depends on) parameters	Value type
0.25	0.85	0.35	<b>Digital Output No.1 usage scenarios (ID=1600)</b>	Float

### 8.6.3 Max Cornering Angle (ID=1604)

It is max allowed cornering angle which can be reached while cornering without triggering harsh cornering event.

Minimum value	Maximum value	Recommended value	Goes with (depends on) parameters	Value type
0	255	23	<b>Digital Output No.1 usage scenarios (ID=1600)</b>	U16

### 8.6.4 Max allowed Speed (ID=1605)

It is max allowed speed which can be reached. If this value exceeded Over speeding event will occur.

Minimum value	Maximum value	Recommended value	Goes with (depends on) parameters	Value type
0	260	-	<b>Digital Output No.1 usage scenarios (ID=1600)</b>	U16

### 8.6.5 Digital Output No.2 usage scenarios (ID=1601)

Device can operate in its scenario according to selected value: No Scenario for Digital No.2 selected (value 0); Authorized Driving (value 1), Immobilizer (value 2).

Minimum value	Maximum value	Recommended value	Goes with (depends on) parameters	Value type
0	2	-	<b>iButton List (ID=1610-1659)</b>	U8

### 8.6.6 Trip (ID=1280)

This parameter enables ability to detect START and STOP of the trip.

Minimum value	Maximum value	Recommended value	Goes with (depends on) parameters	Value type
0	1	-		U8

### 8.6.7 Start Speed (ID=1281)

This parameter represents speed, which is detected as minimum speed to indicate TRIP START and generate event.

Minimum value	Maximum value	Recommended value	Goes with (depends on) parameters	Value type
0	256	-	<b>Trip (ID=1280)</b>	U8

### 8.6.8 Ignition Off Timeout (ID=1282)

This parameter represents timeout to wait if ignition is off in order to detect TRIP STOP and generate event.

Minimum value	Maximum value	Recommended value	Goes with (depends on) parameters	Value type
0	65535	-	<b>Trip (ID=1280)</b>	U16

### 8.6.9 Trip Continuous distance counting (ID=1283)

For this feature IO#11 ODOMETER must be enabled. If IO ODOMETER is enabled, and Continuous distance counting variable is set to Continuous (value 1), TRIP distance is going to be counted continuously (from TRIP start to TRIP stop) and shown as IO ODOMETER value.

Minimum value	Maximum value	Recommended value	Goes with (depends on) parameters	Value type
0	1	-	<b>Trip (ID=1280) 8.7 IO#11 – Odometer (ID = 1410-1415)</b>	U8

### 8.6.10 Geofencing

In this chapter it is explained how to get all parameters for the first Geofence zone (all ID numbers are for the 1st zone). And at the end of the chapter (part 8.6.10) is presented a table with the IDs of all the rest Geofence zones.

#### 8.6.10.1 Frame border (ID=1020)

Geofence border thickness, measured in meters.

Minimum value	Maximum value	Recommended value	Goes with (depends on) parameters	Value type
100	9999999	1000	<b>All Geofencing parameters</b>	U32

#### 8.6.10.2 Geofence Zone #1 Shape (ID=1030)

Geofence shape parameter can be: circle – value 0; rectangular – value 1.

Minimum value	Maximum value	Recommended value	Goes with (depends on) parameters	Value type
0	1	-	<b>All Geofencing parameters</b>	U8

#### 8.6.10.3 Geofence Zone #1 Priority (ID=1031)

Parameter defines Geofence priority: 0 is low, 1 – high, 2 – panic;

Minimum value	Maximum value	Recommended value	Goes with (depends on) parameters	Value type
0	2	-	<b>All Geofencing parameters</b>	U8

#### 8.6.10.4 Geofence Zone #1 Generate Event (ID=1032)

Generate event on entering zone – value 0; on exiting zone – value 1; on both – value 2;

Minimum value	Maximum value	Recommended value	Goes with (depends on) parameters	Value type
0	3	-	<b>All Geofencing parameters</b>	U8

#### 8.6.10.5 Geofence Zone #1 Longitude (X1) (ID=1033)

Parameter has two meanings dependent on zone shape. If shape is rectangular, then ID=10333 is left down corner X coordinate. If shape is circle, then ID=1033 is center of that circle X coordinate.

Sample value: 25.30528

Minimum value	Maximum value	Recommended value	Goes with (depends on) parameters	Value type
-180	180	-	<b>All Geofencing parameters</b>	Float

#### 8.6.10.6 Geofence Zone #1 Latitude (Y1) (ID=1034)

Parameter has two meanings dependent on zone shape. If shape is rectangular, then ID=1034 is left down corner Y coordinate. If shape is circle, then ID=1034 is center of that circle Y coordinate.

Minimum value	Maximum value	Recommended value	Goes with (depends on) parameters	Value type
-90	90	-	<b>All Geofencing parameters</b>	Float

#### 8.6.10.7 Geofence Zone #1 Longitude (X2) (ID=1035)

Parameter has two meanings dependent on zone shape. If shape is rectangular, then ID=1035 is right upper corner X coordinate. If shape is circle, then ID=1035 is radius of circle with center of ID=1033 and ID=1034.

*For rectangular:*

Minimum value	Maximum value	Recommended value	Goes with (depends on) parameters	Value type
-180	180	-	<b>All Geofencing parameters</b>	Float

*For circle:*

Minimum value	Maximum value	Recommended value	Goes with (depends on) parameters	Value type
0	2147483647	1000	<b>All Geofencing parameters</b>	Float

#### 8.6.10.8 Geofence Zone #1 Latitude (Y2) (ID=1036)

If shape is rectangular, then ID=1036 is right upper corner Y coordinate. If shape circle, ID=1036 is not used.

Minimum value	Maximum value	Recommended value	Goes with (depends on) parameters	Value type
-90	90	-	<b>All Geofencing parameters</b>	Float

Other 4 GeoFence zone's parameters have the same logic as shown in GeoFence Zone #1.

GeoFence Zone Number	Geofence Zone's parameters
1	1030-1036
2	1040-1046
3	1050-1056
4	1060-1066
5	1070-1076

### 8.6.11 AutoGeofencing

#### 8.6.11.1 Enable/Disable (ID=1101)

Enable – value 0; disable – value 1;

Minimum value	Maximum value	Recommended value	Goes with (depends on) parameters	Value type
0	1	1		U8

#### 8.6.11.2 Activation Timeout (ID=1102)

Parameter represents AutoGeofencing activation timeout in seconds.

Minimum value	Maximum value	Recommended value	Goes with (depends on) parameters	Value type
0	65535	60	<b>Enable/Disable (ID=1101)</b>	U16

#### 8.6.11.3 Deactivate by (ID=1100)

Parameter defines AutoGeofence deactivation source. Value 1 is dedicated for attached iButton, value 0 – for Ignition.

Minimum value	Maximum value	Recommended value	Goes with (depends on) parameters	Value type
0	1	-	<b>Enable/Disable (ID=1101)</b> <b>iButton List (ID=1610-1659)</b>	U8

#### 8.6.11.4 AutoGeofence event Priority (ID=1103)

Parameter defines AutoGeofence event priority: 0 is low, 1 – high;

Minimum value	Maximum value	Recommended value	Goes with (depends on) parameters	Value type
0	1	1	<b>Enable/Disable (ID=1101)</b> <b>AutoGeofence event generating (ID=1104)</b>	U8

#### 8.6.11.5 AutoGeofence event generating (ID=1104)

Generate event: on entering zone – value 0; on exiting zone – value 1; on both – value 2;

Minimum value	Maximum value	Recommended value	Goes with (depends on) parameters	Value type
0	3	2	<b>Enable/Disable (ID=1101)</b> <b>AutoGeofence event Priority (ID=1103)</b>	U8

#### 8.6.11.6 Radius (ID=1105)

Parameter represents radius of circle with center device coordinates after activating AutoGeofence feature.

Minimum value	Maximum value	Recommended value	Goes with (depends on) parameters	Value type
0	42949672 95	100	<b>Enable/Disable (ID=1101)</b> <b>Deactivate by (ID=1100)</b>	U32

### 8.6.12 iButton List (ID=1610-1659)

*Read 5.4.4.*

Minimum value	Maximum value	Recommended value	Goes with (depends on) parameters	Value type
0	FFFFFFFF FFFFFFFF	-	<b>Digital Output No.2 usage scenarios (ID=1601)</b> <b>Deactivate by (ID=1100)</b>	U64

## 8.7 IO parameters

IO properties – are additional data sources which are recorded along with usual GPS data.

### 8.7.1 IO#1 property parameter (ID=1300)

Parameter defines IO property value. Possible values: enabled (value 1), disabled (value 0).

Minimum value	Maximum value	Recommended value	Goes with (depends on) parameters	Value type
0	byte	-	<b>IO#1 priority (ID=1301)</b> <b>IO#1 High level (ID=1302)</b> <b>IO#1 Low level (ID=1303)</b> <b>IO#1 logic operand (ID=1304)</b> <b>IO#1 averaging length (ID=1305)</b>	S8

### 8.7.2 IO#1 priority (ID=1301)

Parameter defines IO property type of priority: 0 is low, 1 – high, 2 – panic, 3 – security priority type.

Minimum value	Maximum value	Recommended value	Goes with (depends on) parameters	Value type
0	3	0	<b>IO#1 property parameter (ID=1300)</b> <b>IO#1 High level (ID=1302)</b> <b>IO#1 Low level (ID=1303)</b> <b>IO#1 logic operand (ID=1304)</b> <b>IO#1 averaging length (ID=1305)</b>	S8

### 8.7.3 IO#1 High level (ID=1302)

Parameter defines high value of triggered IO property. This parameter is used to set thresholds for IO properties to generate events.

Minimum value	Maximum value	Recommended value	Goes with (depends on) parameters	Value type
-2147483648	2147483648	1	<b>IO#1 property parameter (ID=1300)</b> <b>IO#1 priority (ID=1301)</b> <b>IO#1 Low level (ID=1303)</b> <b>IO#1 logic operand (ID=1304)</b> <b>IO#1 averaging length (ID=1305)</b>	S32

#### 8.7.4 IO#1 Low level (ID=1303)

Parameter defines low value of triggered IO property. This parameter is used to set thresholds for IO properties to generate events.

Minimum value	Maximum value	Recommended value	Goes with (depends on) parameters	Value type
-2147483648	2147483648	0	<b>IO#1 property parameter (ID=1300)</b> <b>IO#1 priority (ID=1301)</b> <b>IO#1 High level (ID=1302)</b> <b>IO#1 logic operand (ID=1304)</b> <b>IO#1 averaging length (ID=1305)</b>	S32

#### 8.7.5 IO#1 logic operand (ID=1304)

Parameter defines when event is sent: 0: on range exit, 1: on range entrance, 2: both, 3: monitoring.

Minimal value	Maximum value	Recommended value	Goes with (depends on) parameters	Value type
0	3	3	<b>IO#1 property parameter (ID=1300)</b> <b>IO#1 priority (ID=1301)</b> <b>IO#1 High level (ID=1302)</b> <b>IO#1 Low level (ID=1303)</b> <b>IO#1 averaging length (ID=1305)</b>	S8

#### 8.7.6 IO#1 averaging length (ID=1305)

Parameter defines IO property sample length to average. If no averaging needed default value is 1.

Minimum value	Maximum value	Recommended value	Goes with (depends on) parameters	Value type
0	2147483648	1	<b>IO#1 property parameter (ID=1300)</b> <b>IO#1 priority (ID=1301)</b> <b>IO#1 High level (ID=1302)</b> <b>IO#1 Low level (ID=1303)</b> <b>IO#1 logic operand (ID=1304)</b>	S32

Other IO property elements are configuring in same logic. All IO elements parameter list is below.

<b>IO Element Number</b>	<b>IO element parameters</b>
IO#0 – Digital input 1	1300 – 1305
IO#1 – Digital input 2	1310 – 1315
IO#2 – Digital input 3	1320 – 1325
IO#3 – Analog input	1330 – 1335
IO#4 – Digital output 1	1340 – 1345
IO#5 – Digital output 2	1350 – 1355
IO#6 – PDOP	1360 – 1365
IO#7 – HDOP	1370 – 1375
IO#8 – Power voltage	1380 – 1385
IO#9 – GPS power	1390 – 1395
IO#10 – Movement sensor	1400 – 1405
IO#11 – Odometer	1410 – 1415
IO#12 – Actual operator Code	1420 – 1425
IO#13 – Speedometer	1430 – 1435
IO#14 – iButton ID	1440 – 1445
IO#15 – Operating Mode	1450 – 1455
IO#16 – GSM Signal	1460 – 1465
IO#17 – Deep Sleep	1470 – 1475
IO#18 – Cell ID	1480 – 1485
IO#19 – Area Code	1490 – 1495
IO#20 – Temperature	1500 – 1505

## 9 MOUNTING RECOMMENDATIONS

### 9.1 *Connecting Wires*

- Wires should be connected while module is not plugged in.
- Wires should be fastened to the other wires or non-moving parts. Try to avoid heat emitting and moving objects near the wires.
- The connections should not be seen very clearly. If factory isolation was removed while connecting wires, it should be applied again.
- If the wires are placed in the exterior or in places where they can be damaged or exposed to heat, humidity, dirt, etc., additional isolation should be applied.
- Wires cannot be connected to the board computers or control units.

### 9.2 *Connecting Power Source*

- Be sure that after the car computer falls asleep, power is still available on chosen wire. Depending on a car, this may happen in 5 to 30 minutes period.
- When module is connected, be sure to measure voltage again if it did not decrease.
- It is recommended to connect to the main power cable in the fuse box.

### 9.3 *Connecting Ignition Wire*

- Be sure to check if it is a real ignition wire – power does not disappear while starting the engine.
- Check if this is not an ACC wire (when key is in the first position, most electronics of the vehicle are available).
- Check if power is still available when you turn off any of vehicles devices.
- Ignition is connected to the ignition relay output. As alternative, any other relay, which has power output, when ignition is on, may be chosen.

### 9.4 *Connecting Ground Wire*

- Ground wire is connected to the vehicle frame or metal parts that are fixed to the frame.
- If the wire is fixed with the bolt, the loop must be connected to the end of the wire.
- For better contact scrub paint from the place where loop is connected.

### 9.5 *Connecting Antennas*

- When placing antennas avoid easily reached places.
- Avoid GPS antenna placement under metal surfaces.
- Avoid placing FM1100 device near car radio, speakers or alarm systems.
- GPS antenna must be placed so its state is as horizontal as possible (if antenna is leant more than 30 degrees, it is considered incorrect mounting).
- GPS antenna cable cannot be bent more than 80 degrees.
- GPS antenna must be placed sticker facing down



Figure 36 GPS antenna correct mounting.

It is recommended to place GPS antenna behind dashboard as close to the window as possible. A good example of GPS antenna placement is displayed in a picture below (area colored green).

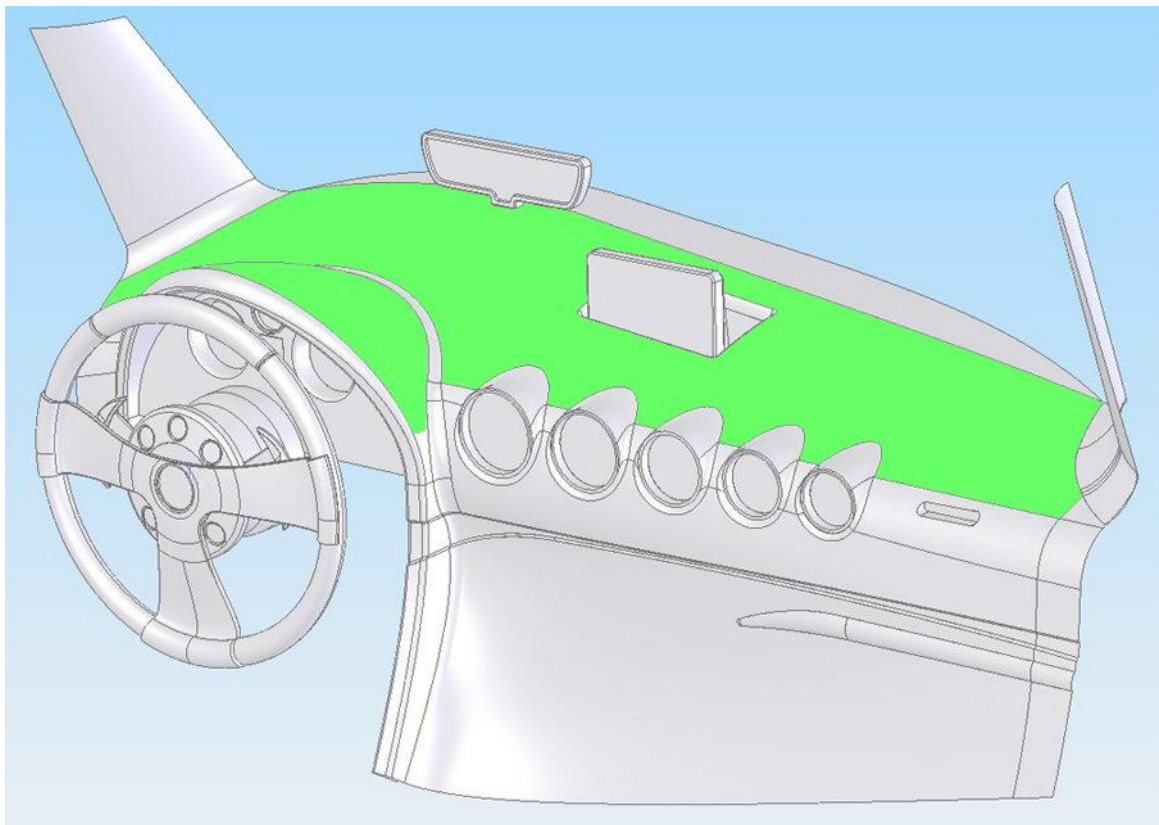

Figure 11. Correct placement of FM1100

### 9.6 Module Installation

- Module should not be seen or easily reached.
- Module should be firmly fixed to the surface or cables.
- Module cannot be fixed to heat emitting or moving parts.
- SIM card should be inserted in the module while the connector is plugged off (while module has no power).

## 10 CHANGE LOG

Nr.	Date	Version	Comments
1	2011-04-15	0.3	Preliminary draft release.
2	2011-04-20	0.4	Preliminary draft release update.
3	2011-04-21	0.5	Preliminary draft release update.
4	2011-04-26	0.6	Preliminary draft release update.
5	2011-04-27	0.7	Preliminary draft release update.
6	2011-05-12	0.8	Preliminary draft release update.
7	2011-05-27	0.9	Preliminary draft release update.
8	2011-06-02	0.10	Preliminary draft release update.
9	2011-06-21	0.11	Preliminary draft release update.
10	2011-07-28	0.12	Preliminary draft release update.
11	2011-08-18	0.13	Preliminary draft release update.
12	2011-10-19	0.14	TTJ connection scheme update.
13	2011-11-02	0.15	Static Navigation mode added.